

Owner's manual

Oasis

COVANA



COVANA

SPA COVER MANUFACTURER

OWNER'S MANUAL



MANUAL NO. 262012

OASIS COVER

MANUAL NO. 262012

First edition 2026-01-19

REVISION	DESCRIPTION	DATE
0	OWNER'S MANUAL NEW RELEASE	2026-01-19
1	INSTRUCTIONS FOR SNOW REMOVAL	2026-03-24
2	ELECTRICAL DIAGRAMS UPDATE	2026-05-25

CONGRATULATIONS!	8
IMPORTANT INFORMATION	9
SAFETY	9
DRUGS AND ALCOHOL	9
IMPORTANT SAFETY INSTRUCTIONS	10
RISK OF ELECTROCUTION	11
ELECTRICAL WARNING	12
MODIFICATIONS TO THE COVER	12
LABELING	14
PARTS NAME AND QUANTITY	16
INSTALLATION PROCEDURE	18
TOOLS REQUIRED	18
PREPARATION FOR THE INSTALLATION	19
HARDWARE IDENTIFICATION TABLE	21
ASSEMBLY PREPARATION	22
LIFTING MECHANISM INSTALLATION (PART 1)	23
AC LIGHTING SYSTEM	28
LIFTING MECHANISM INSTALLATION (PART 2)	30
TESTING THE COVER	32
KEY SWITCH INSTALLATION	34
NON-PERMANENT MOUNTING PLATES (OPTIONAL)	35
SEAL INSTALLATION	36
ELECTRICAL CONNECTIONS	39
LIMIT SWITCH ADJUSTMENT	40
OPERATE THE COVER	46
RAISING/LOWERING THE COVER WITH THE KEY SWITCH	46
LED LIGHTS	47
MANUAL OPERATION OF THE COVER	48
WIRE GUARD REASSEMBLY	49
ELECTRICAL DIAGRAMS	52
WIRING DIAGRAM (NORTH AMERICA) (LIGHTS) – 60 HZ, 120 VAC OPERATOR	53
WIRING DIAGRAM (EUROPE) (LIGHTS) – 50 HZ, 230 VAC OPERATOR	54
MAINTENANCE	56
WASHING THE COVER	56
WINTERIZING	56
POST GREASING	57
CHAIN LUBRICATION	59
PERIODIC MAINTENANCE SCHEDULE - OASIS	60

TECHNICAL SPECIFICATIONS	62
COVER FRONT VIEW	62
FRAME DIMENSIONS AND FOOT PRINT	63
CONCRETE SLAB LAYOUT OPTION	64
ELECTRICAL SPECIFICATIONS	65
TROUBLESHOOTING	68

SAFETY AND IMPORTANT INSTRUCTIONS

CONGRATULATIONS!

Congratulations for the purchase of your new COVANA cover!

IMPORTANT NOTE



PLEASE REGISTER
YOUR COVER AT THE
TIME OF PURCHASE
TO ENSURE A PROPER
FOLLOW-UP PROCESS.

COVANA.COM/EN/WARRANTY-REGISTRATION

NOTE



FOR SERVICE
AND ADVICE,
DO NOT HESITATE
TO CALL YOUR
LOCAL AUTHORIZED
COVANA RETAILER.

IMPORTANT INFORMATION

DANGER, WARNING, CAUTION and NOTE are used throughout this manual to emphasize important points when necessary:

DANGER

Directs your attention to unsafe practices which could result in serious personal injury or death.

WARNING

Directs your attention to unsafe practices which could result in serious personal injury or severe damage to the cover.

CAUTION

Directs your attention to unsafe practices where personal injury is not likely but damage to cover components could occur.

NOTE

Indicates supplementary information essential to the proper operation of the cover, proper installation or proper maintenance.

IMPORTANT NOTE



**READ THIS MANUAL
BEFORE USING
THE COVER.**

NOTE

Illustrations in this manual are used for reference only and may differ from the actual cover; however, key components are represented as accurately as possible.

Keep this manual in a safe location for future reference.

Before reproducing or copying this manual, in whole or in part, written consent must be obtained from Covana. Covana reserves the right to make changes without notice and without incurring any obligation.

SAFETY

The cover was designed, tested and certified to be installed over a spa under important installation instructions issued by Covana. Any other type of usage will void the warranty and product certification.



CAUTION



THE COVER WAS NOT DESIGNED TO SUPPORT ADDITIONAL LOAD OR PEOPLE WALKING OR STANDING ON IT. FAILURE TO FOLLOW THIS INSTRUCTION WILL VOID THE WARRANTY AND ITS CERTIFICATION.

The power safety cover meets ASTM F1346-23 requirements.

DRUGS AND ALCOHOL



DANGER

THE USE OF DRUGS OR ALCOHOL WHILE OPERATING THE COVER IS STRICTLY PROHIBITED. THE IMPAIRMENT OF JUDGMENT, VISION OR HEARING MIGHT AFFECT THE SAFETY OF OTHER PEOPLE OR RESULT IN DEATH.



IMPORTANT SAFETY INSTRUCTIONS

WARNING

KEEP THESE INSTRUCTIONS IN A SAFE LOCATION.
REVIEW THESE INSTRUCTIONS REGULARLY.

NOTE

READ AND FOLLOW ALL INSTRUCTIONS.

WARNING

CALIFORNIA PROPOSITION 65

This product contains chemicals known to the State of California to cause cancer and birth defects or other reproductive harm.

DANGER

- Do not allow children under the age of 18 to use this product unless they are supervised at all times.
- Failure to follow all the instructions may result in injury or even death.
- Do not climb, walk, sit or stand on the cover at any time.
- Never operate the cover until all people and objects are out of the spa.
- Do not operate the cover in extreme wind. See TECHNICAL SPECIFICATIONS section for the wind limitations.

WARNING

- Be sure to keep the key out of the reach of children under the age of 18.
- Do not put any type of fabric or plastic sheet, such as a tarpaulin or canvas, on the cover. This can overheat the cover and cause it to warp.
- Inspect the cover periodically. It should raise smoothly and evenly. Contact your Covana retailer if any unusual mechanical sound is heard during cover operation.

DO'S

- Remove the key from the key switch after operating the cover. Users must bring the key in the spa with them to prevent the unauthorized operation of the cover. Store the key in a secure location when not in use.
- Check the cover frequently for any sign of deterioration.
- Have any repairs, adjustments or mechanical work performed by a certified Covana retailer as soon as possible when you notice any malfunction.
- Completely lower the cover when it is not in use or if the spa is not being monitored.
- The cover should only be operated by an adult.
- This product can be operated by an 8-year-old or older child and persons with reduced physical, sensory or mental capabilities or lack of experience and knowledge **ONLY** if they are supervised by an adult or have received instructions regarding safe use of the cover.
- Children must not play with the product. Cleaning and user maintenance must not be performed by children without supervision.

DON'TS

- Do not operate the unit before all mechanical and electrical connections are completely installed.
- Do not step on or stack anything on the operator cover.
- Do not use an extension cord to supply electrical power to the cover. The extension cord may not be properly grounded, and the connection is an electric shock hazard. An extension cord may cause a voltage drop, which may cause the motor to overheat.

DON'T



DO NOT KEEP THE COVER OPEN FOR MORE THAN 12 CONSECUTIVE HOURS. FAILURE TO FOLLOW THIS INSTRUCTION MAY CAUSE PERMANENT DEFORMATIONS TO THE COVER.



CAUTION

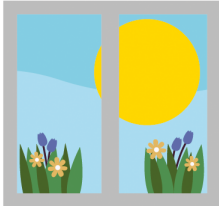

DO NOT CONVERGE OR DIRECTLY REFLECT SUNLIGHT ON THE COVER. THIS COULD CAUSE PERMANENT DAMAGE (E.G.: REFLECTION FROM A WINDOW).



CAUTION

- Use only accessories and tools approved by Covana.
- Do not rotate or slide the cover using its edges. This may damage the edge components.
- When unpacking after delivery or disassembling parts, always keep them in a safe location on a clean and level surface as to not damage them.
- This product mainly contains steel, plastic, fiberglass, foam, copper and die-cast aluminum. Recycle properly according to the local rules.
- The gearbox contains oil and other materials. Recycle properly according to the local rules.
- The jack stroke is limited by two limit switches. These switches are pre-adjusted at the factory. Refer to the LIMIT SWITCH ADJUSTMENT section before making any adjustments. An improper adjustment can result in damage to the operator and/or to the cover.

RISK OF ELECTROCUTION



WARNING



ALL ELECTRICAL CONNECTIONS MUST BE DONE BY A CERTIFIED ELECTRICIAN OTHERWISE THE CERTIFICATION AND WARRANTY WILL BE VOID.



CAUTION

Any modifications to the electrical components will void the warranty.



DANGER

Failure to comply with these instructions may result in death by electrocution or serious injury.



DANGER

- Disconnect or turn off and secure all power supplies before starting any intervention on the cover.
- A circuit breaker needs to be incorporated into the fixed wiring at the time of installation. This circuit breaker must be accessible to the user or service technician to turn the power off for future maintenance or repair.
- Only a certified electrical contractor may perform any electrical maintenance on the cover. The wiring must comply with all applicable local electrical regulations.
- The operator must be connected to a circuit that is protected by a dedicated ground fault circuit interrupter (GFCI) that complies with all applicable local electrical codes and regulations.
- Install the cover in such a way that drainage directs water away from the electrical and the mechanical components at the base.
- Do not connect any auxiliary components to the electrical system of the cover unless they have been approved by Covana.
- Replace electrical components with original components provided or approved by Covana. Ask your retailer for replacement parts.
- To reduce the risk of electric shock, replace a damaged electrical cord immediately. Failure to do so may result in death or serious personal injury due to electrocution.
- Do not bury the electrical wires into the ground unless using a direct-burial underground cable. Not respecting this precaution may result in death, or serious personal injury due to electrocution.

ELECTRICAL WARNING

WARNING

- To reduce the risk of electric shock, the green-colored terminal (or marked “g,” “gr,” “ground,” “grounding” or with a $\frac{1}{\perp}$ symbol) located inside the supply terminal box or compartment must be connected to the grounding connection provided in the electric supply service panel with a continuous copper wire equivalent in size to the circuit conductors supplying the equipment.
- Two lugs marked “bonding lugs” are provided on the external surface or on the inside of the supply terminal box or compartment. To reduce the risk of electric shock, connect the local common bonding grid in the area of the cover. Use terminals with an insulated or bare copper conductor not smaller than no. 6 AWG (4.11 mm / 13.30 mm²).
- All field-installed metal components, such as rails, ladders, drains or other similar hardware, within 10 ft (3 m) of the spa must be bonded to the equipment grounding bus with copper conductors not smaller than no. 6 AWG (4.11 mm / 13.30 mm²) (NEC art. 680).

MODIFICATIONS TO THE COVER

WARNING

Any modifications to the cover, such as mechanical, electrical or aesthetic, may cause the cover to operate in an unwanted or dangerous way. Furthermore, these modifications are not permitted and might void the warranty and certification.

**SAVE THESE
INSTRUCTIONS**

LABELING







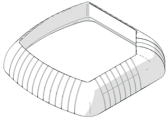

LABELING

<p>Key switch operation diagram</p> <p>➔ On the key switch</p>	<p>Risk of electrocution</p> <p>➔ On the power cable</p>	<p>No step</p> <p>➔ On the top of the operator cover</p>
<p>Technical specifications with serial number (European models)</p> <p>➔ On the operator cover</p>	<p>Proposition 65 (North American models)</p> <p>CALIFORNIA PROPOSITION 65 WARNING</p> <p>WARNING: This product contains chemicals known to the State of California to cause cancer and birth defects or other reproductive harm.</p> <p>For more information: www.P65Warnings.ca.gov</p> <p>➔ On the side of the operator cover</p>	<p>Risk of electrocution</p> <p>WARNING RISK OF INJURY DISCONNECT OR TURN OFF ALL POWER SUPPLY BEFORE STARTING INTERVENTION ON THE SPA COVER</p> <p>AVERTISSEMENT RISQUE DE BLESSURE DÉBRANCHER OU COUPER L'ALIMENTATION ÉLECTRIQUE AVANT TOUTE INTERVENTION SUR LE COUVERCLE DE SPA</p> <p>ADVERTENCIA RIESGO DE LESIONES DESCONECTAR O APAGAR LA CORRIENTE ELÉCTRICA ANTES DE COMENZAR A TRABAJAR EN LA CUBIERTA DEL SPA</p> <p>➔ On the operator</p>
<p>Technical specifications with serial number (North American models)</p> <p>➔ On the operator cover</p>	<p>Maintenance information</p> <p>Visit www.covana.com for recommended maintenance procedures and videos This label not to be removed except by the consumer</p> <p>Visitez www.covana.com pour des conseils et des vidéos sur les procédures d'entretien Seul l'utilisateur peut retirer cet autocollant</p> <p> MADE IN CANADA / FABRIQUÉ AU CANADA</p> <p>➔ On one side of the outer shell</p>	<p>Avoid drowning</p> <p>WARNING AVOID DROWNING RISK. ENTRAPMENT POSSIBLE. FAILURE TO FOLLOW ALL INSTRUCTIONS MAY RESULT IN INJURY OR DROWNING. INSPECT COVER PERIODICALLY. POWER SAFETY COVER MEETS ASTM F1346-23 REQUIREMENTS. FOR FURTHER INFORMATION CONTACT: WWW.COVANA.COM</p> <p>➔ On the four exterior and interior wall faces of the cover</p>

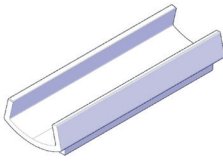
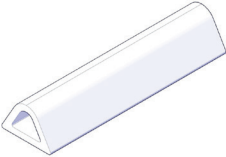
! WARNING

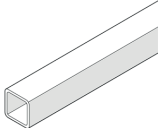
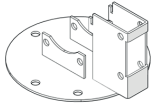
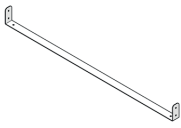
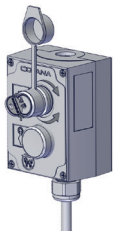
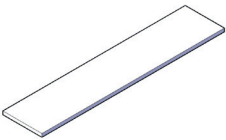
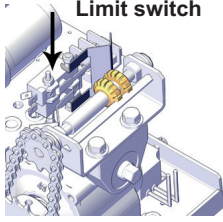
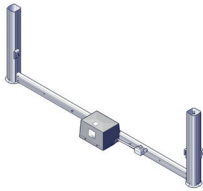
REMOVING ANY LABEL ON THE COVER WILL VOID THE PRODUCT CERTIFICATION. ALL LABELS SHOULD ALWAYS REMAIN VISIBLE. IT IS THE OWNER'S RESPONSIBILITY TO ENSURE THAT THE LABELS ARE ALWAYS VISIBLE AND NEVER REMOVED.

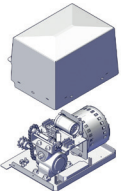
PARTS NAME AND QUANTITY

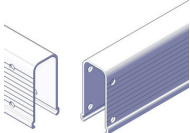
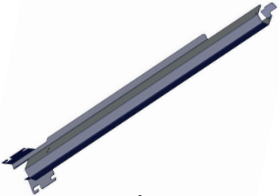
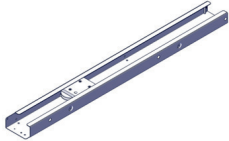
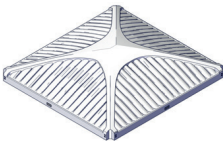
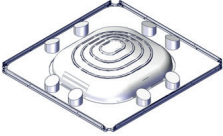
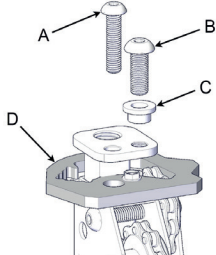
<p>All-weather seal</p>  <p>4x</p>	<p>Seal</p>  <p>1x</p>	<p>Seal clip</p>  <p>26x</p>	<p>Seal connector</p>  <p>1x</p>
<p>Outer corner bracket</p>  <p>4x</p>	<p>Drive shaft</p>  <p>2x</p>	<p>Foot plate</p>  <p>4x</p>	<p>U-frame link</p>  <p>1x</p>
<p>Key switch</p>  <p>1x</p>	<p>Foam spacer</p>  <p>8x</p>	<p>Limit switch</p>  <p>2x</p>	<p>Motor frame</p>  <p>1x</p>
<p>Jack</p>  <p>2x motor 2x non-motor</p>	<p>Operator</p>  <p>1x</p>	<p>Sleeve</p>  <p>4x</p>	<p>U-frame</p>  <p>2x long 2x short</p>
<p>Wire guard</p>  <p>1x</p>	<p>CTS-70</p>  <p>1x</p>	<p>Outer shell</p>  <p>1x</p>	<p>Inner shell</p>  <p>1x</p>
 <p>A: Jack lock screw B: Top plate screw C: Bushing D: Alignment bracket (plastic)</p>			

















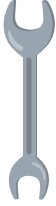
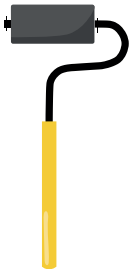

INSTALLATION AND PREPARATION

INSTALLATION PROCEDURE

CAUTION

The cover must be installed by a certified Covana installer (two people are required for certain steps). Having the cover installed by someone who is not certified will void the warranty.

TOOLS REQUIRED

<p>Power drill</p> 	<p>Rubber mallet</p> 	<p>Scissors</p> 	<p>25' (7.62 m) Measuring tape</p> 
<p>24" (61 cm) level</p> 	<p>SAE or metric socket kit</p> 	<p>1/2" Wrench (12.7 mm)</p> 	<p>J-Roller with rubber roller</p> 
<p>Phillips screwdriver</p>  	<p>Robertson screwdriver</p>  	<p>Flat blade screwdriver</p>  	<p>Step ladder</p> 
<p>No. 2 x 6" Robertson drive bit</p> 	<p>7/32" (5.5 mm) Allen key</p> 	<p>Screws to secure key switch Key switch holes: \varnothing 0.195"</p>  <p>2 x OR 4x</p>	<p>Concrete anchor bolts OR lag bolts for wood Bracket holes: \varnothing 0.37"</p>  <p>OR</p> <p>8x</p>

PREPARATION FOR THE INSTALLATION

To ensure safe use of the cover, it must be installed on a properly prepared surface (Figure 2).

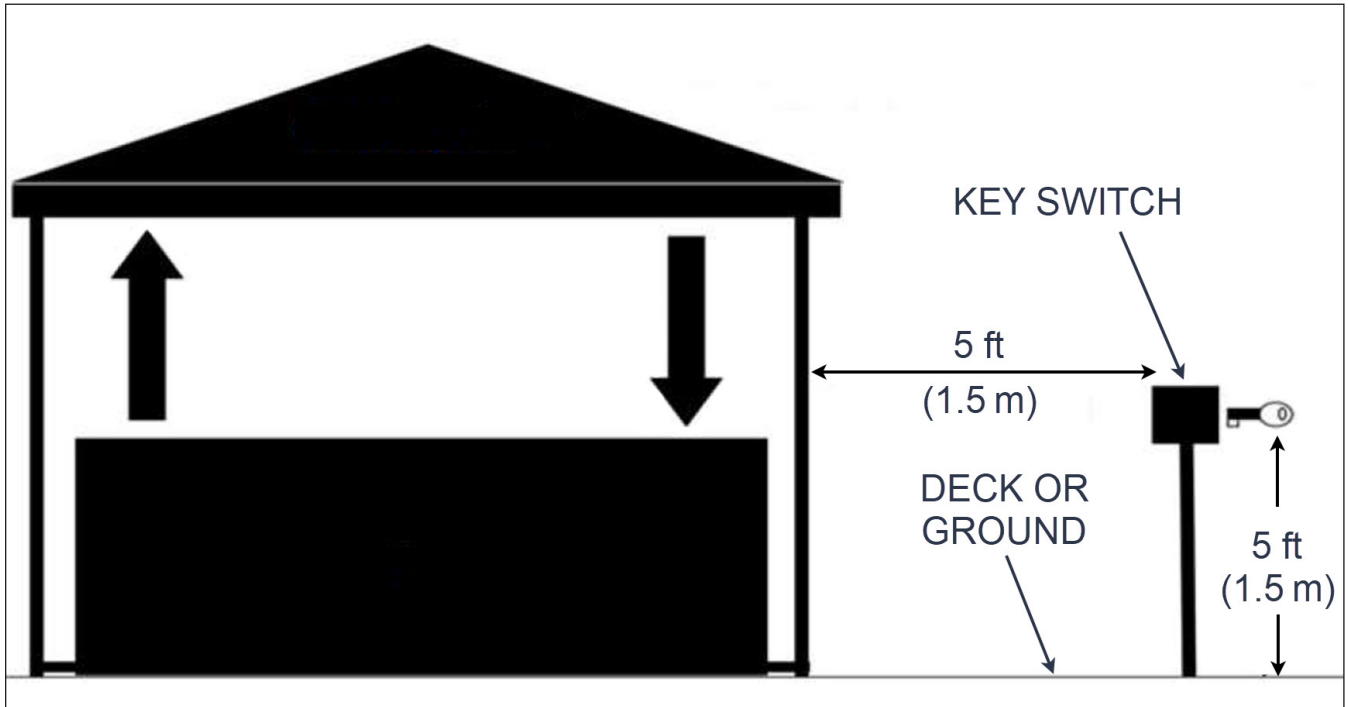

FIGURE 1: POSITION OF THE KEY SWITCH

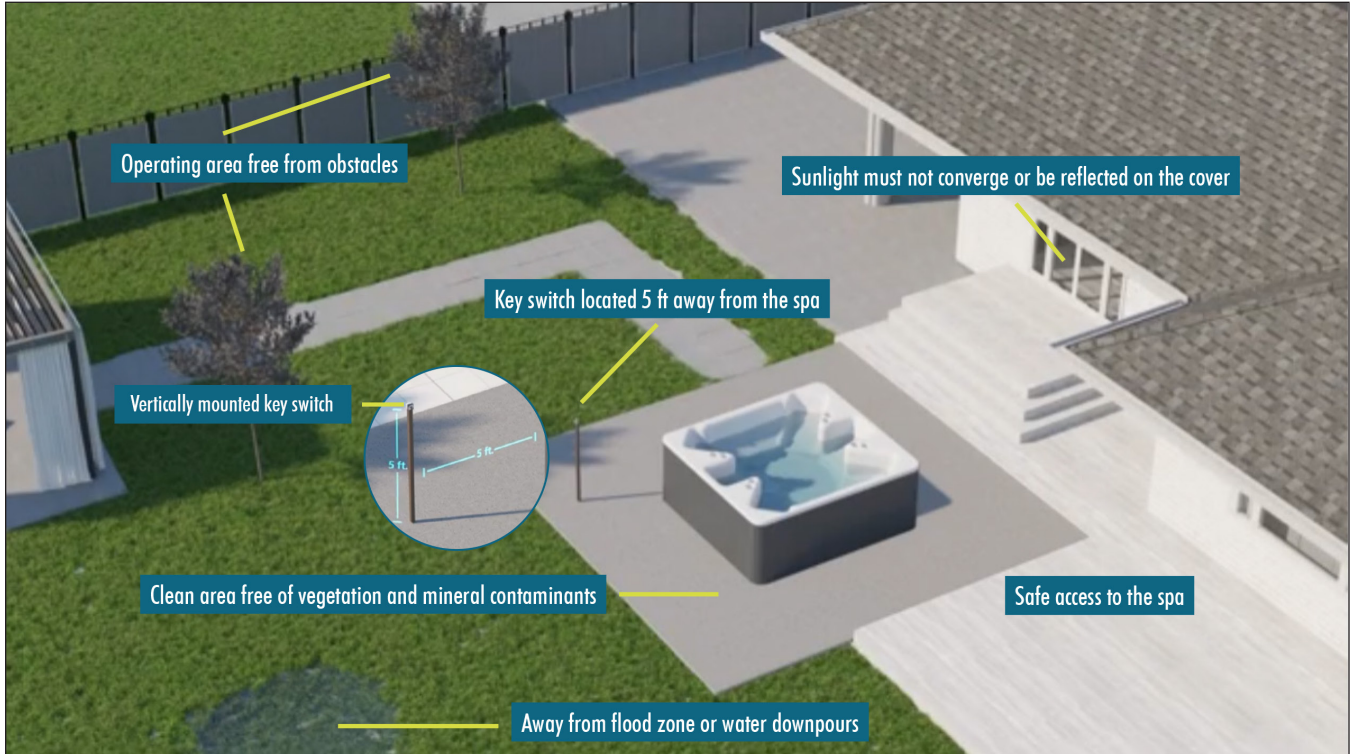

FIGURE 2: PREPARATION FOR THE INSTALLATION

FOUNDATION PREPARATION

The cover requires a clean, flat and level surface such as an engineered wood deck or a concrete slab.

The four jacks must be properly anchored to the foundation. If you cannot meet this requirement, install a set of non-permanent mounting plates.

For an existing foundation, refer to the diagram in the TECHNICAL SPECIFICATIONS section.

FIGURE 3: FOUNDATION DIAGONAL

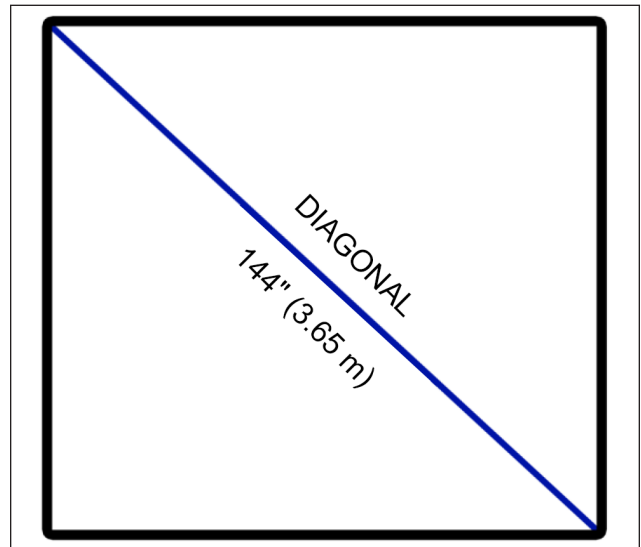

WARNING

THE FOUNDATION MUST BE ABLE TO SUPPORT AT LEAST 600 LB. (272 KG)

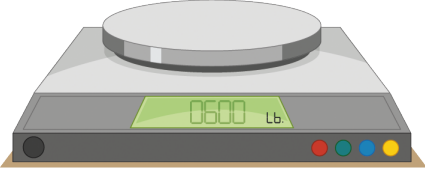









WARNING

- The foundation must be leveled with a maximum tolerance of 1" (25 mm) over a diagonal section (Figure 3). Refer to the minimum base size of the foot print in the TECHNICAL SPECIFICATIONS section.
- The annual variation in levelness for the same diagonal section cannot exceed 1/4" (6 mm).

CAUTION

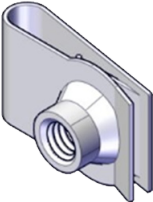
- Damage caused by inadequate foundation construction is not covered by the warranty. It is the responsibility of the owner to provide a proper foundation.
- Failure to follow these guidelines might cause permanent damage or improper functioning of the cover. Such damage might not be covered by the warranty.

HARDWARE IDENTIFICATION TABLE

<p>A</p> <p>16x No. 8 x 1/2"</p>  <p>255679</p>	<p>B</p> <p>18x M6 x 20 mm</p>  <p>255676</p>	<p>C</p> <p>4x 1/4-20 x 3/4"</p>  <p>202013 Slate 202014 Mocha</p>
<p>D</p> <p>16x 5/16-18 x 2"</p>  <p>202000 Slate 202001 Mocha</p>	<p>E</p> <p>4x 1/4-20 x 2 1/4"</p>  <p>188801</p>	<p>F</p> <p>2x M6</p>  <p>202159</p> <p>G</p> <p>8x 1/4-20 16x 5/16-18</p>  <p>213128 (1/4) 202002 Slate (5/16) 202003 Mocha (5/16)</p>
<p>H</p> <p>16x 1/4" painted 32x 5/16" nylon</p>  <p>198684 (5/16) 201998 Slate (1/4) 201999 Mocha (1/4)</p>	<p>I</p> <p>2x 1/4"</p>  <p>224035</p>	<p>J</p> <p>2x 8-32 x 3/8"</p>  <p>200368</p>

HARDWARE IDENTIFIED IN IMAGES THROUGHOUT INSTALLATION REFERS TO THIS PAGE

NOTE: Extra parts are included in case some break or are lost during installation

ASSEMBLY PREPARATION

FIGURE 4: INSTALL FOAM SPACERS

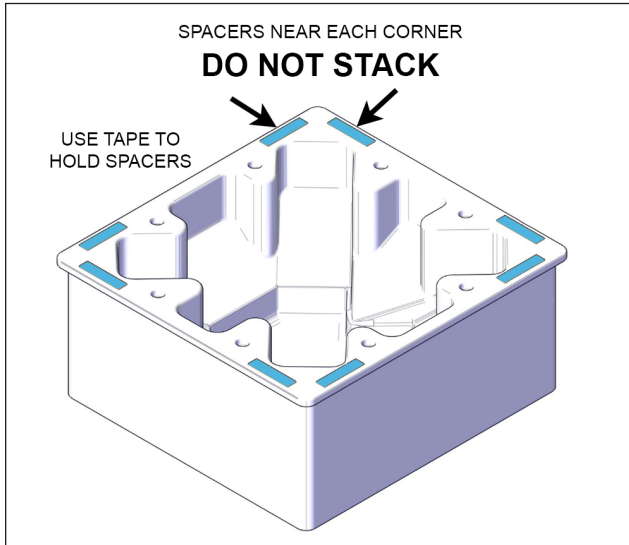



CAUTION



PLACE SPACERS ON THE FLAT TOP SURFACE OF THE SPA.

NO PROTRUDING HEADRESTS

FIGURE 5: THE COVER IS RECTANGULAR

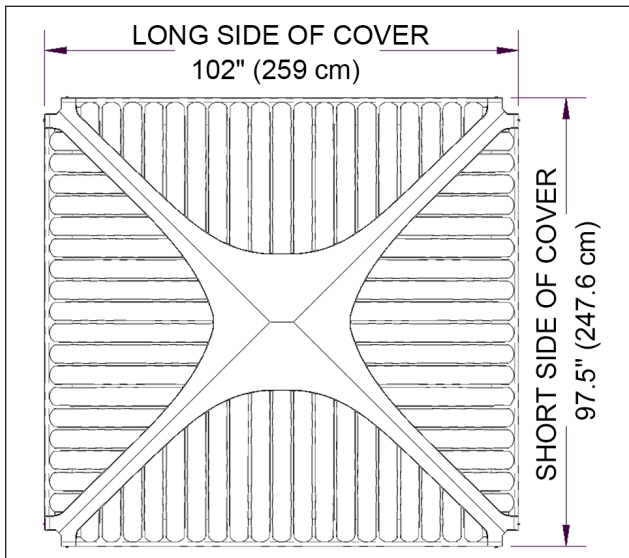
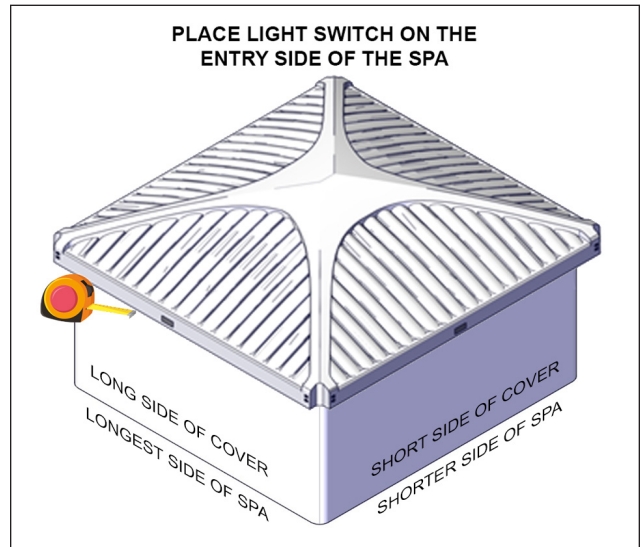



FIGURE 6: CENTER COVER ON SPA





WARNING

- The cover alone weighs approximately 185 lb. (84 kg).
- When handling the cover, 2 people must support the outer and inner shells with both hands. A wide grip is best when handling the cover, as all four sides must be lifted equally.
- 3 to 4 people may be required. Remove the outer shell if the cover is too heavy to handle. Be careful not to fold the outer shell or scratch it on the inner steel frame.

LIFTING MECHANISM INSTALLATION (PART 1)



WARNING

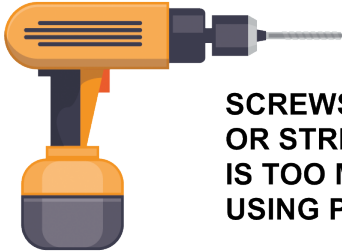

SCREWS MAY BREAK OR STRIP IF THE TORQUE IS TOO MUCH WHEN USING POWER TOOLS.



WARNING

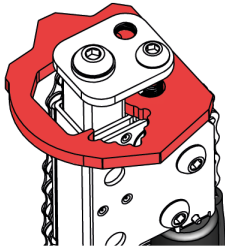

DO NOT REMOVE THE ALIGNMENT BRACKET ON THE TOP OF THE JACK (PLASTIC PART).

NOTE

The next steps are side-specific. They are for the non-motor left-hand side foot assembly.

Install the motor frame (usually to the opposite side of the spa entrance).

- Standard and XL models: motor frame on the short side of the cover.
- PLUS model: motor frame on the long side of the cover.

FIGURE 7: LOCATION OF OPERATOR AND JACKS

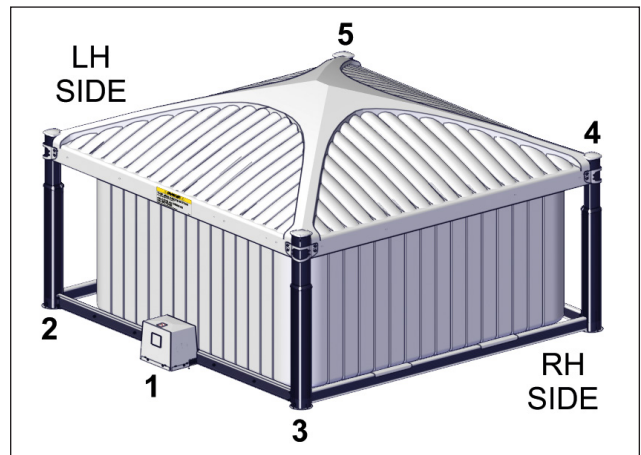

1	OPERATOR
2	MOTOR LEFT-HAND SIDE JACK
3	MOTOR RIGHT-HAND SIDE JACK
4	NON-MOTOR RIGHT-HAND SIDE JACK
5	NON-MOTOR LEFT-HAND SIDE JACK

FIGURE 8: INSTALL FOOT BRACKET ON THE NON-MOTOR LEFT-HAND SIDE JACK

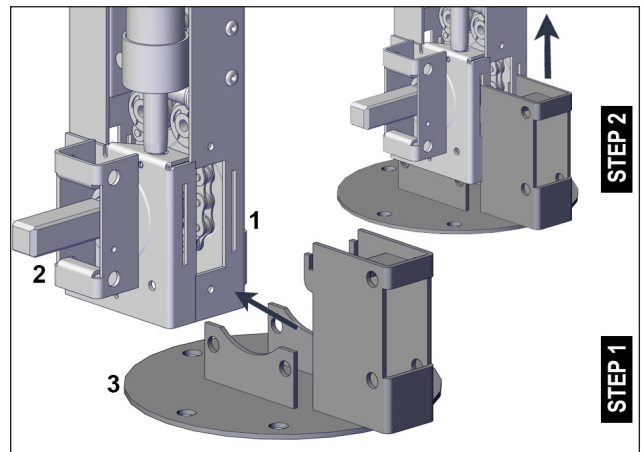

1	NON-MOTOR LEFT-HAND SIDE JACK
2	RIGHT-HAND SIDE OF U-FRAME
3	FOOT BRACKET

FIGURE 9: INSTALL FOOT BRACKET ON THE NON-MOTOR RIGHT-HAND SIDE JACK

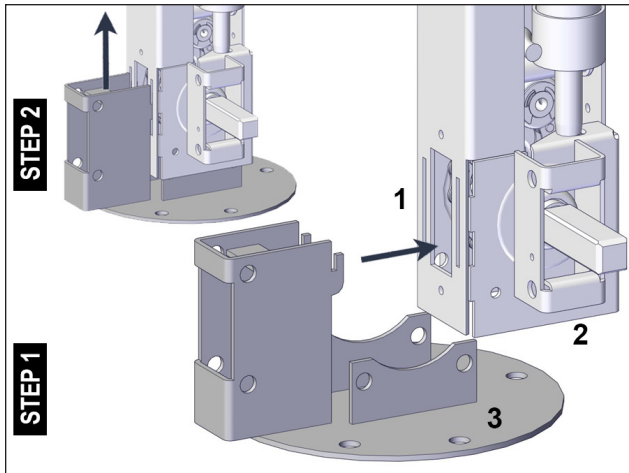

1	NON-MOTOR RIGHT-HAND SIDE JACK
2	RIGHT-HAND SIDE OF U-FRAME
3	FOOT BRACKET

FIGURE 10: INSTALL SCREWS AND NUTS ON LEFT-HAND AND RIGHT-HAND NON-MOTOR SIDE JACKS

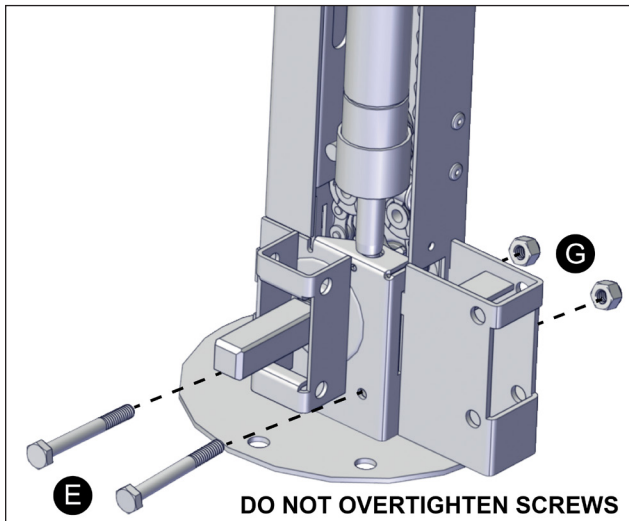

E	1/4-20 x 2 1/4" HEXAGONAL HEAD SCREWS
G	1/4-20 NYLON-INSERT LOCK NUTS

⚠ CAUTION

Lay the posts down before proceeding with the next step.

- Place the non-motor left-hand side jack in the remaining corner of the cover; the square shaft facing the motor frame, and the U-frame bracket facing inward.

FIGURE 11: SLIDE DRIVE SHAFT OVER SQUARE SHAFT

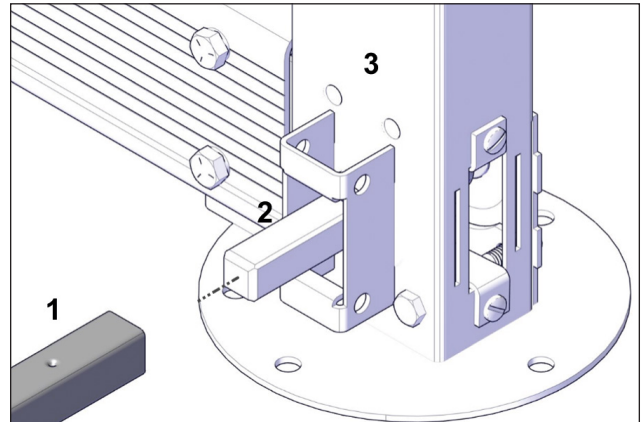

1	DRIVE SHAFT
2	SQUARE SHAFT
3	MOTOR LEFT-HAND SIDE JACK

- Hold the non-motor left-hand side jack upright and in line with the left drive shaft.

FIGURE 12: SLIDE DRIVE SHAFT OVER SQUARE SHAFT

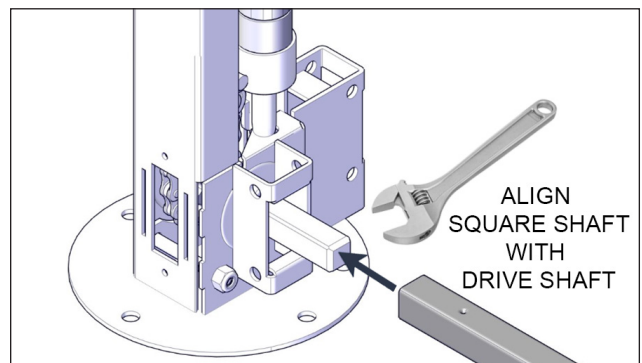

⚠ WARNING

Using the jack without the drive shaft properly connected may cause injury.

FIGURE 13: INSTALL LONG U-FRAME

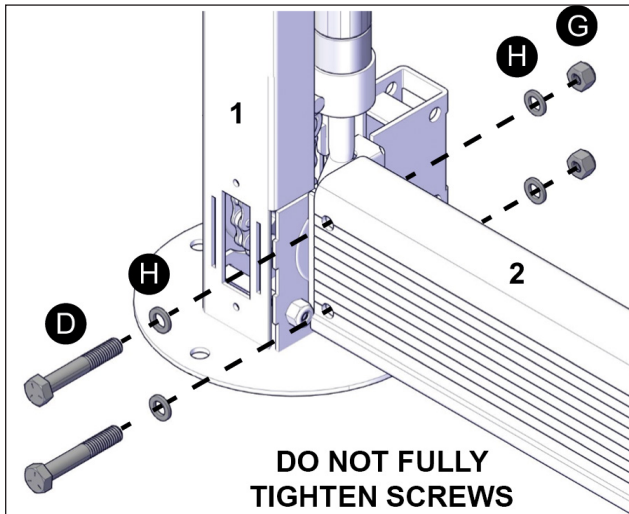

D	5/16-18 x 2" HEX HEAD SCREWS
G	5/16-18 NYLON INSERT LOCK NUTS
H	5/16" NYLON WASHERS
1	NON-MOTOR SIDE JACK
2	LONG U-FRAME

- Repeat previous steps on the opposite side.

FIGURE 14: FASTEN ONE METAL COUPLER ON EACH END OF SPA ENTRANCE U-FRAME LINK

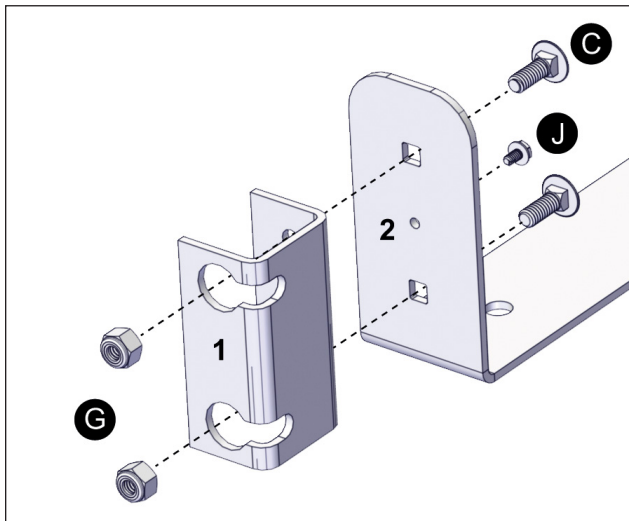

C	1/4-20 x 3/4" CARRIAGE BOLT
G	5/16-18 NYLON INSERT LOCK NUTS
J	8-32 x 3/8" HEX SLOTTED THREAD-CUTTING SCREW
1	UNPAINTED METAL COUPLER
2	SPA ENTRANCE U-FRAME LINK

- Fasten a short U-frame to each end of the spa entrance U-frame link (Figure 14).

FIGURE 15: FASTEN SHORT U-FRAMES

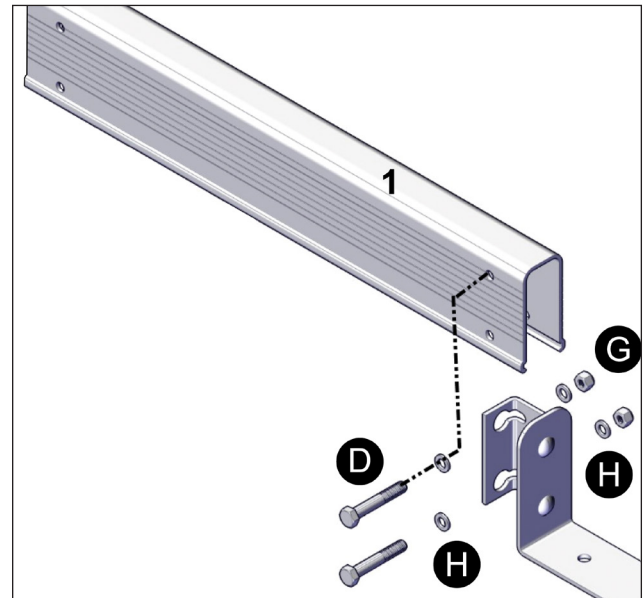

D	5/16-18 x 2" HEX HEAD SCREWS
G	5/16-18 NYLON INSERT LOCK NUTS
H	5/16" NYLON WASHERS
1	SHORT U-FRAME

FIGURE 16: SLIDE ASSEMBLY BETWEEN FRONT POSTS



FIGURE 17: FASTEN ASSEMBLY TO FRONT POSTS

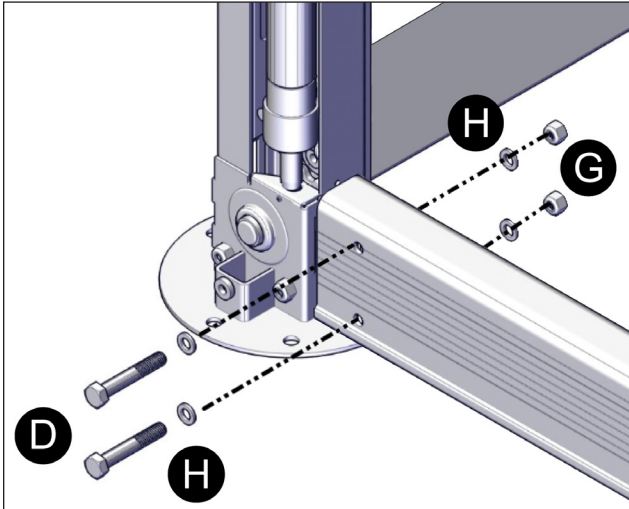

D	5/16-18 x 2" HEX HEAD SCREWS
G	5/16-18 NYLON INSERT LOCK NUTS
H	5/16" NYLON WASHERS

- Tighten all U-frame screws (make sure the drive shafts didn't fall off. If so, review the previous steps).

! **DANGER**



FAILURE TO VERIFY THE PROPER INSTALLATION OF THE DRIVE SHAFTS COULD RESULT IN THE NON-MOTOR-SIDE JACKS EXTENDING ON THEIR OWN.

! **CAUTION**

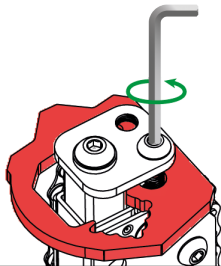

FAILURE TO REMOVE THE LOCKING SCREWS WILL DAMAGE THE LIFTING MECHANISM WHEN OPERATING.

FIGURE 18: REMOVE JACK LOCK SCREW (1), SOCKET SCREW (2) AND BUSHING (3). KEEP THEM FOR FUTURE USE

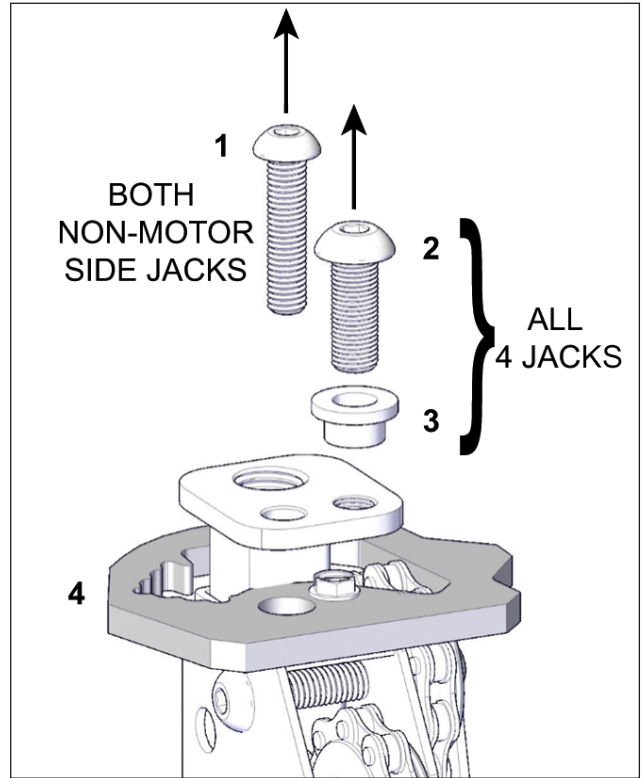

1	M8 x 50 mm JACK LOCK SCREW
2	3/8" x 1" SOCKET HD SCREW
3	BUSHING
4	ALIGNMENT BRACKET (PLASTIC)

FIGURE 19: INSTALL CLIP-ON BARREL NUT

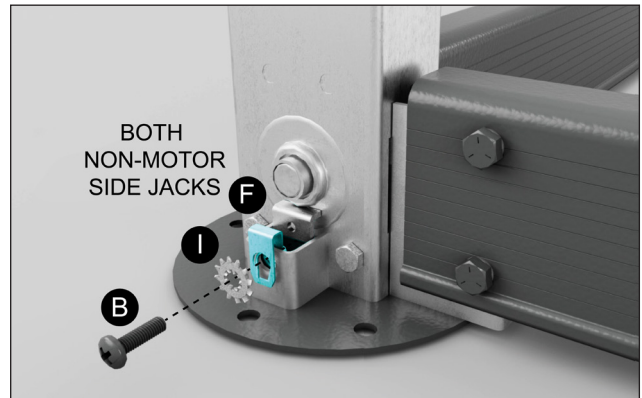

B	M6 x 20 mm SCREW (do NOT fully screw)
F	CLIP-ON BARREL NUT
I	1/4" INT./EXT. TOOTH LOCKWASHER

FIGURE 20: SLIDE SLEEVES OVER FOUR JACKS

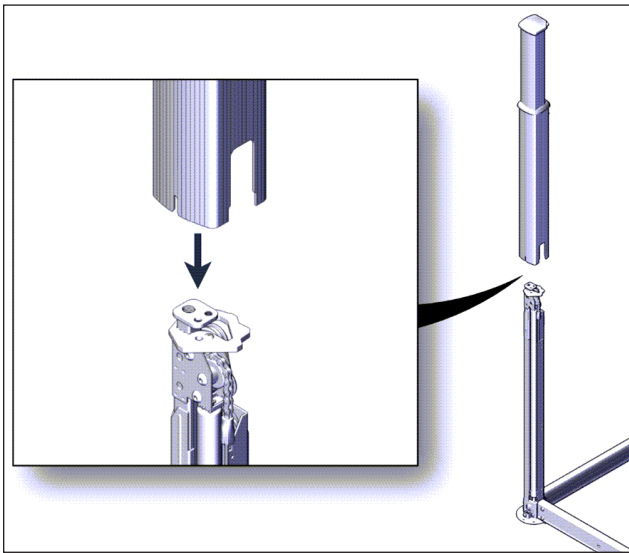
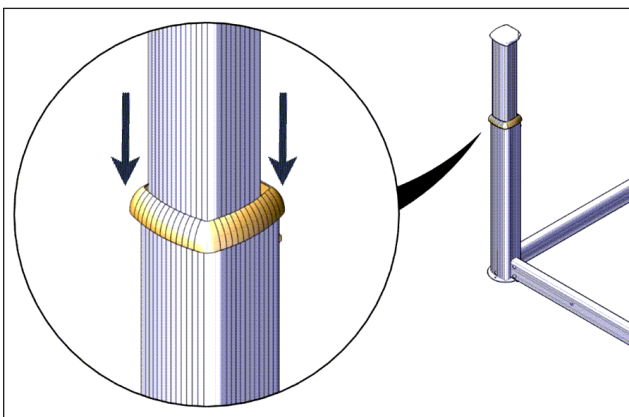

FIGURE 21: TIGHTEN SCREW ON EACH SLEEVE



FIGURE 22: SLIDE SLEEVE SEAL DOWN ON EACH OUTER SLEEVE



⚠ WARNING

Failing to properly position the seal may cause serious damage to the post mechanism.

FIGURE 23: INSTALL 3/8" X 1" SCREW AND BUSHING

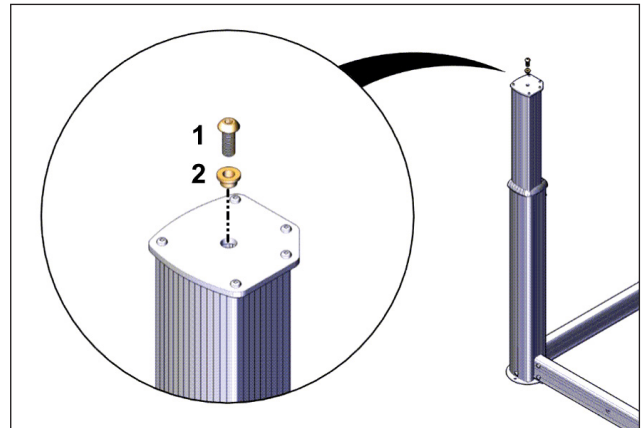

- | | |
|---|---------------------------|
| 1 | 3/8" x 1" SOCKET HD SCREW |
| 2 | BUSHING |

FIGURE 24: CENTER THE COVER

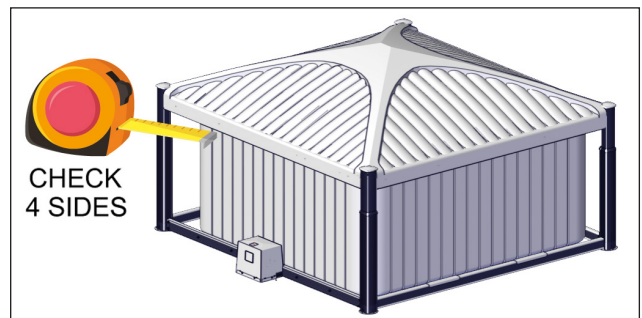
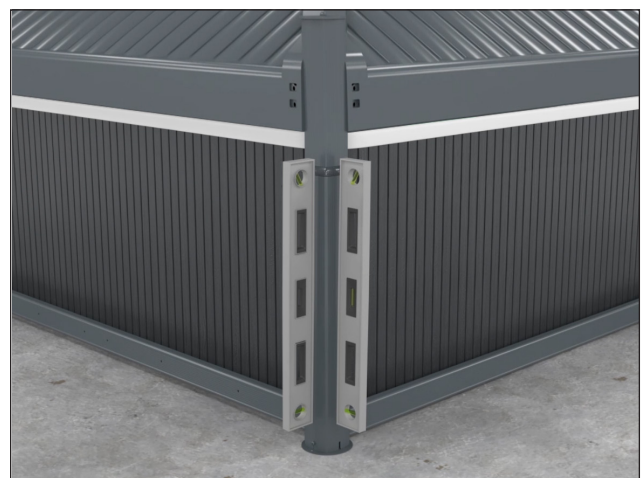

FIGURE 25: CHECK IF POSTS ARE LEVEL



AC LIGHTING SYSTEM

- Lift the side of the outer shell opposite to the light switch button (16" max) (Figure 25). To do so, push on the steel frame of the inner shell to clear the metal inserts from the outer shell (Figure 26).

FIGURE 26: LIFT ONE SIDE OF THE OUTER SHELL

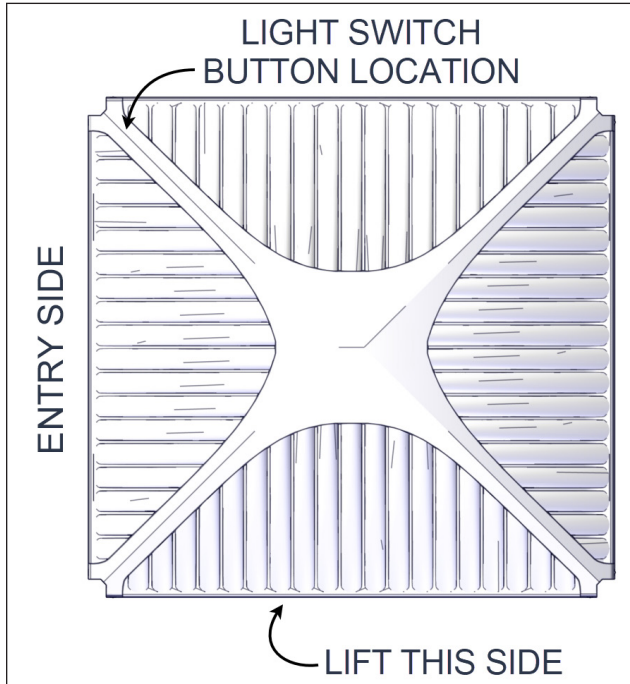

⚠ CAUTION

Always hold the outer shell at two different points spaced by about 34".

FIGURE 27: USE BLUNT TOOL TO HOLD SHELL IN PLACE

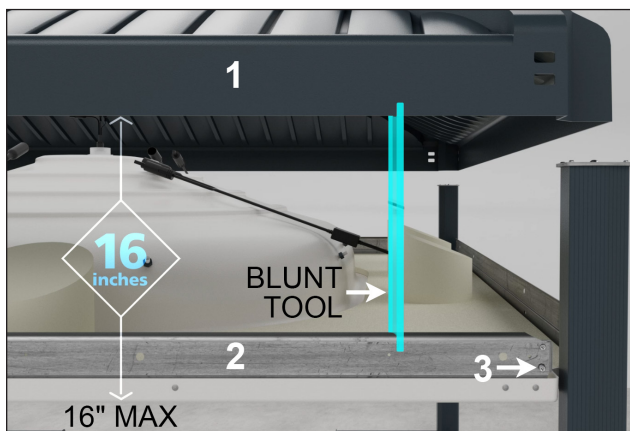

1	OUTER SHELL
2	STEEL FRAME (INNER SHELL)
3	METAL INSERT

FIGURE 28: REMOVE AND DISCARD BOTH CABLE TIES

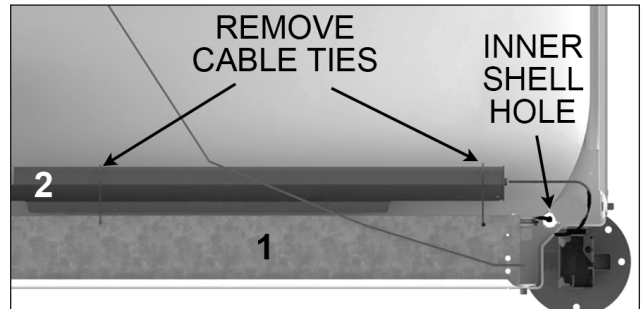

1	CTS-70 (Continuous Tension System)
2	WIRE GUARD

FIGURE 29: REMOVE WIRE GUARD FROM INNER SHELL (LET IT HANG DOWN)



⚠ WARNING

Ensure the wire is clear of the inner and outer shells. It should only hang from the inner shell hole (Figure 27).

FIGURE 30: LOOSEN U-FRAME SCREWS (OPPOSITE CORNER OF THE LIGHT SWITCH BUTTON)

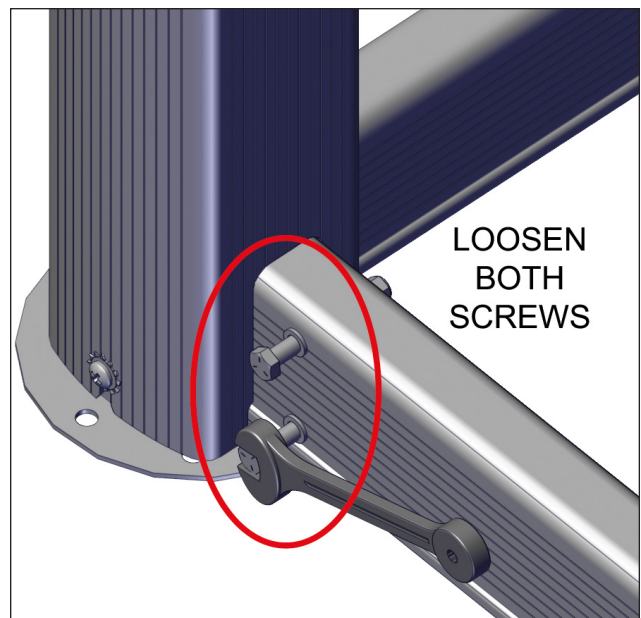



FIGURE 31: INSERT SLOTS OVER LOOSEN SCREWS

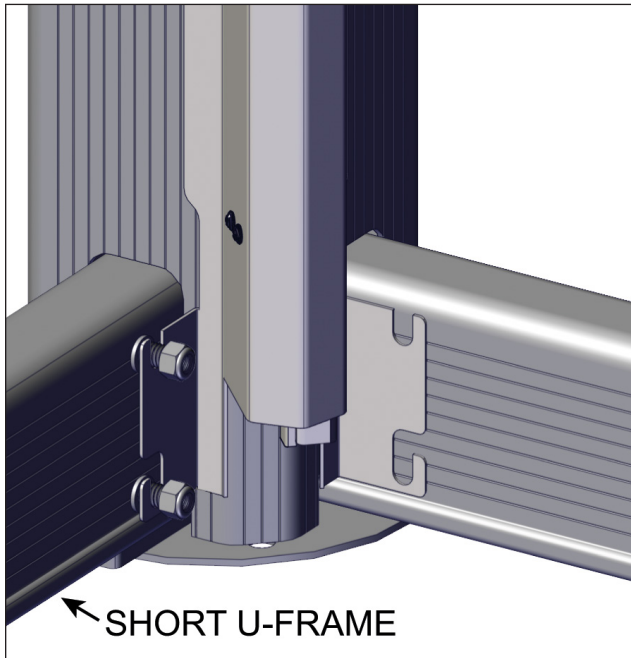

FIGURE 32: INSERT TAB BEHIND PLASTIC HOLDER

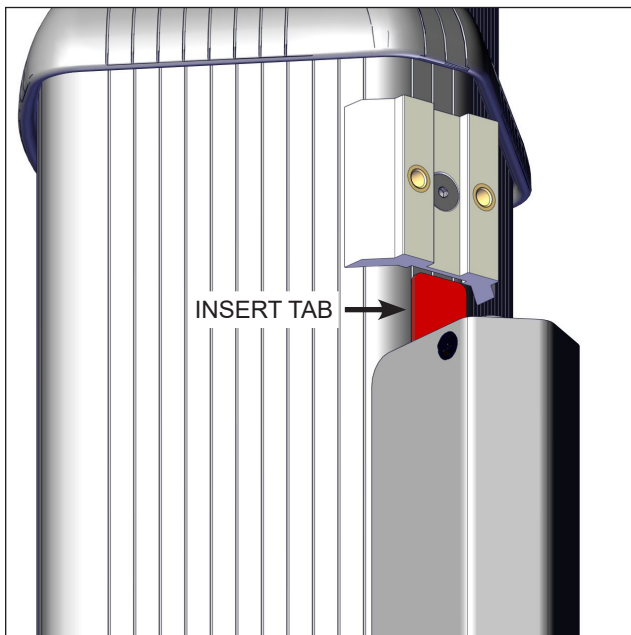

FIGURE 33: TIGHTEN BOTH SCREWS ON U-FRAME

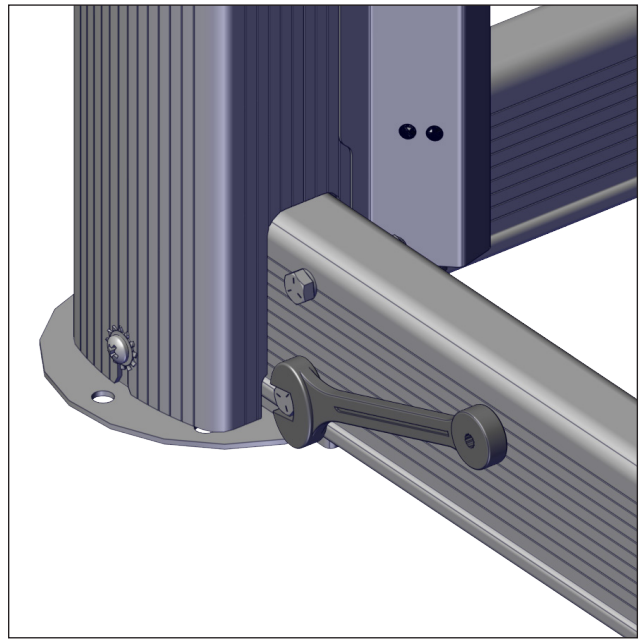
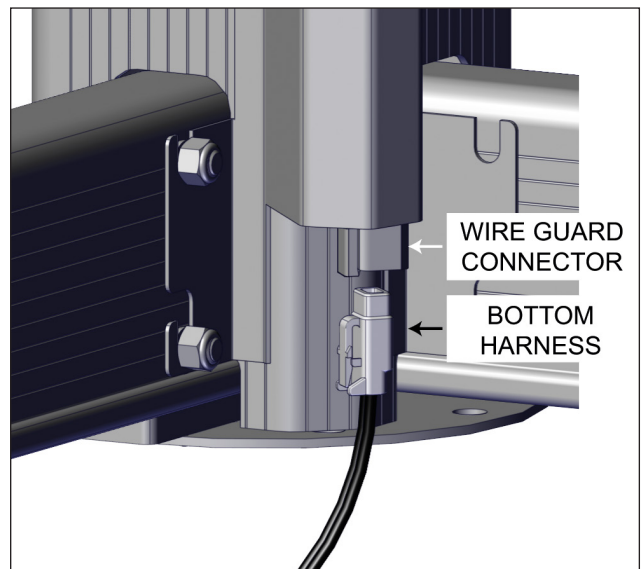

FIGURE 34: CONNECT BOTTOM HARNESS TO WIRE GUARD CONNECTOR



- Lower the cover on the spa.
- If the exiting wire has sufficient tension and the magnetic plate is properly positioned (Figure 34), slide the outer shell back on the inner shell.
- **If not**, loosen the tension holder screws and pull back the tension wire until a slight resistance is felt (Figure 35). Once the resistance is felt, pull another inch. If the wire going to the post is tight enough, retighten the screws. Slide the outer shell back on the inner shell.

FIGURE 35: MAGNETIC PLATE PROPERLY POSITIONED

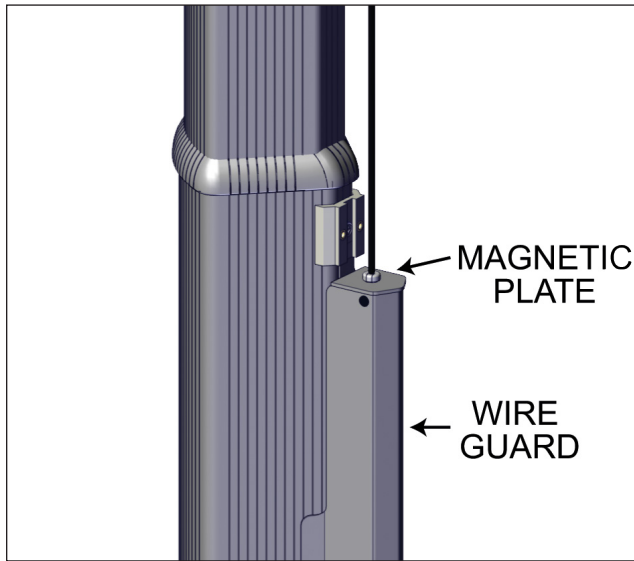
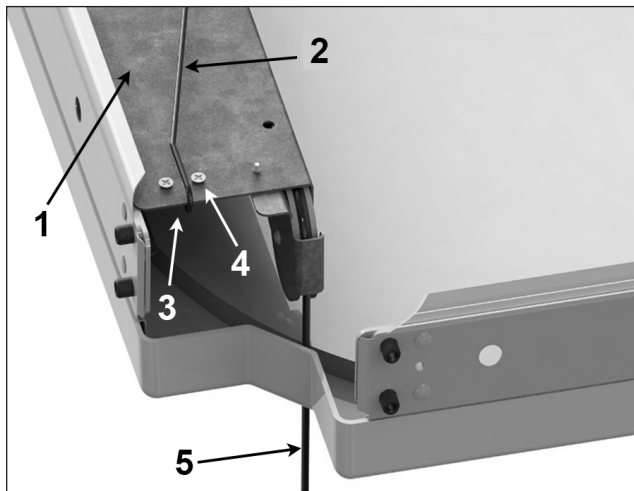

FIGURE 36: IF WIRE DOESN'T HAVE SUFFICIENT TENSION



1	CTS-70
2	TENSION WIRE (GOING TO LED)
3	TENSION HOLDER
4	SCREW
5	EXITING WIRE (GOING TO OPERATOR)

CAUTION

WHEN REINSTALLING THE OUTER SHELL, MAKE SURE THAT THE STEEL FRAMES ARE INSIDE THE OUTER SHELL. ALSO, CHECK ALL THE METAL INSERTS.

LIFTING MECHANISM INSTALLATION (PART 2)

FIGURE 37: INSTALL OUTER CORNER BRACKETS FOLLOWING THIS PATTERN

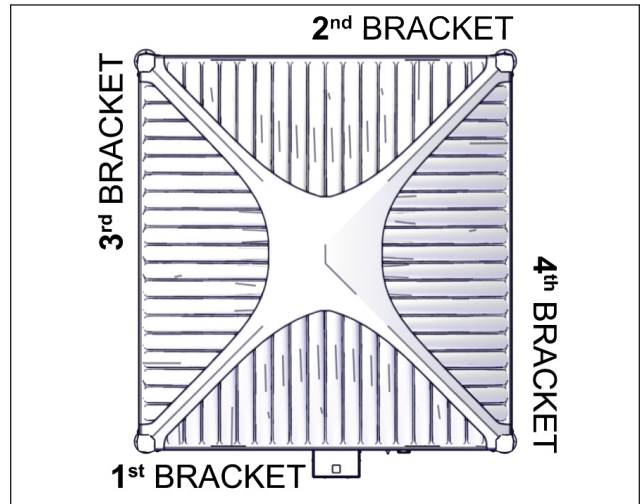

WARNING

Make sure the sleeve is correctly pressed against the outer shell before installing the screws.

FIGURE 38: INSTALL CORNER BRACKET SCREWS FOLLOWING THIS PATTERN

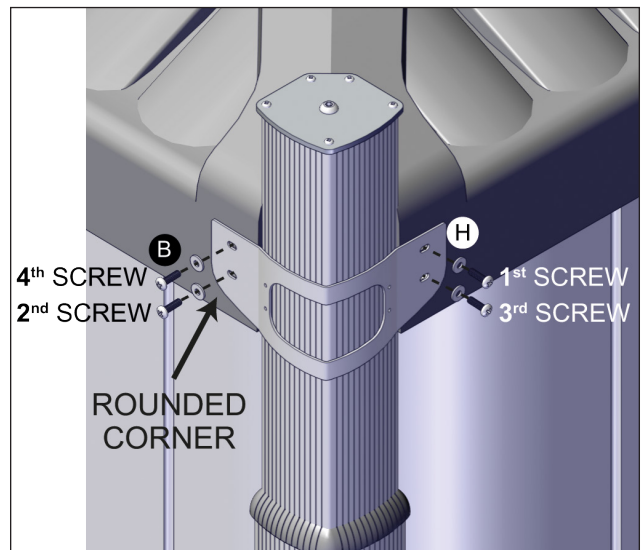

B	M6 x 20 mm SCREWS
H	1/4" PAINTED WASHERS

CAUTION



CHECK IF THE POSTS ARE LEVEL BEFORE DRIVING IN THE SCREWS; IT IS VERY DIFFICULT TO REPOSITION THE SLEEVES ONCE SCREWED.

NOTE

When fastening in the screws, push the post towards the cover for a better fit of the corner bracket.

FIGURE 39: INSTALL CORNER BRACKET SCREWS FOLLOWING THIS PATTERN

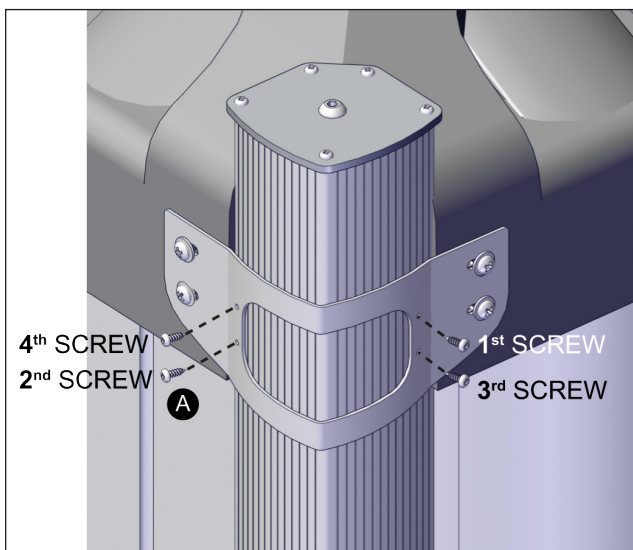

A No. 8 x 1/2" SELF-TAPPING SCREWS

FIGURE 40: AVOID GAP

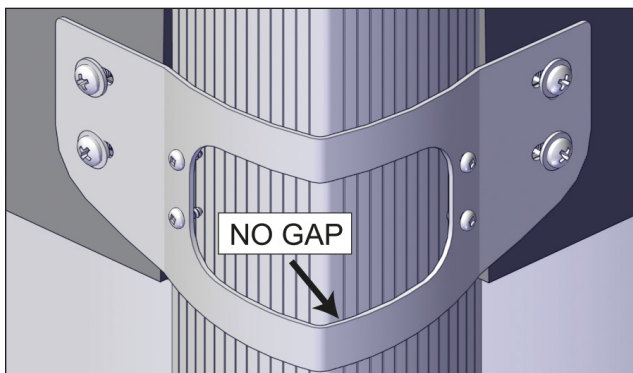

- Repeat previous steps for each corner.

FIGURE 41: INSTALL RUBBER CAP ON EACH POST

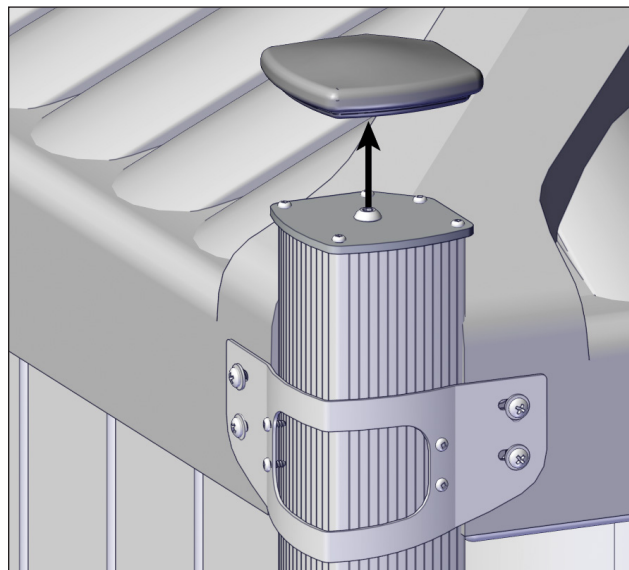

TESTING THE COVER

- Plug in the cover.

FIGURE 42: NO OBJECT ALLOWED ABOVE COVER (SEE LIMIT SWITCH ADJUSTMENT SECTION)



FIGURE 43: RAISE 8" — MAKE SURE COVER LIFTS EVENLY



- Check the installation of the brackets by trying to lift each sleeve. Review **LIFTING MECHANISM INSTALLATION (PART 2)** for any broken screws or to retighten screws if the sleeve keeps moving (Figure 43).

FIGURE 44: CHECK BRACKET INSTALLATION

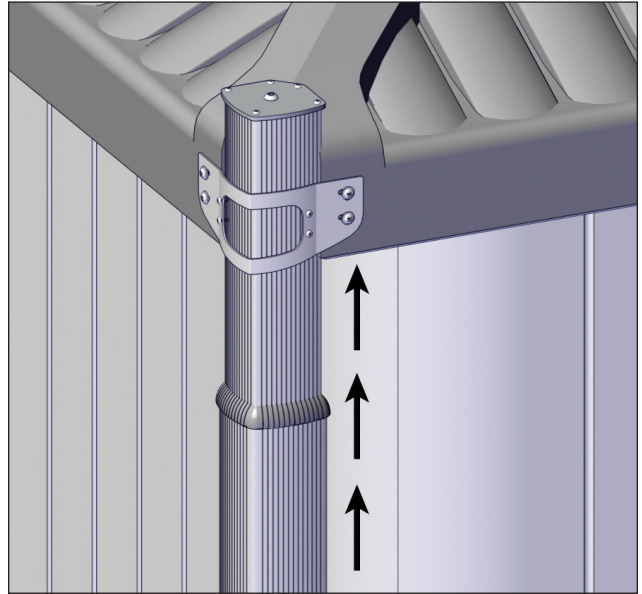
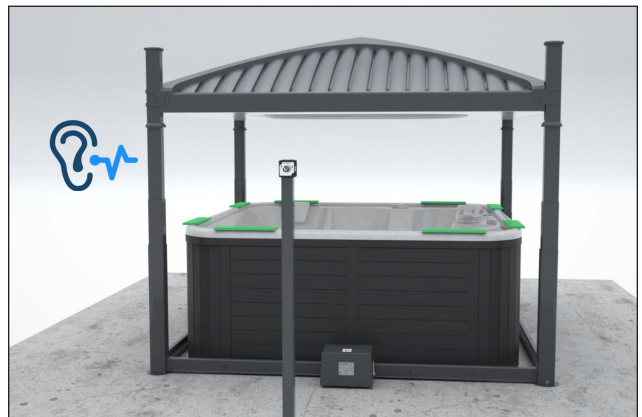

FIGURE 45: LOWER COVER — MUST TOUCH FOAM SPACERS



FIGURE 46: RAISE COVER — LISTEN FOR UNUSUAL SOUNDS



- Lower the cover and make sure it touches the foam spacers. If not, adjust the corner brackets.

FIGURE 47: LOWER COVER — MUST TOUCH FOAM SPACERS

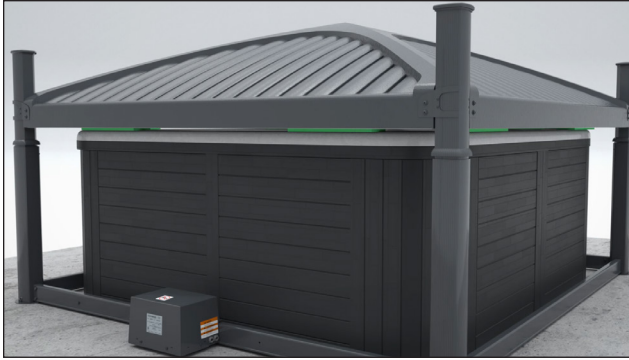
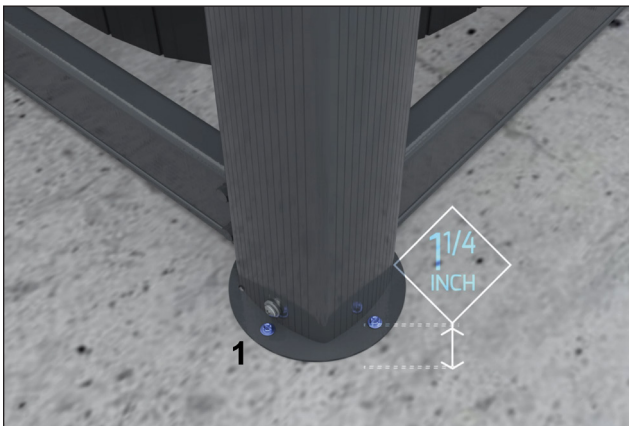

FIGURE 48: CHECK IF POSTS ARE STILL LEVEL



- Anchor jacks to the foundation (in at least one hole in the foot) and **insert at least 1¼" deep**.

FIGURE 49: ANCHOR JACKS TO THE FOUNDATION



1	1/4" CONCRETE ANCHOR BOLT OR 1/4" LAG BOLT FOR WOOD FOUNDATION
----------	---

- If you cannot meet these requirements, install NON-PERMANENT MOUNTING PLATES (OPTIONAL).

FIGURE 50: OR USE NON-PERMANENT MOUNTING PLATES

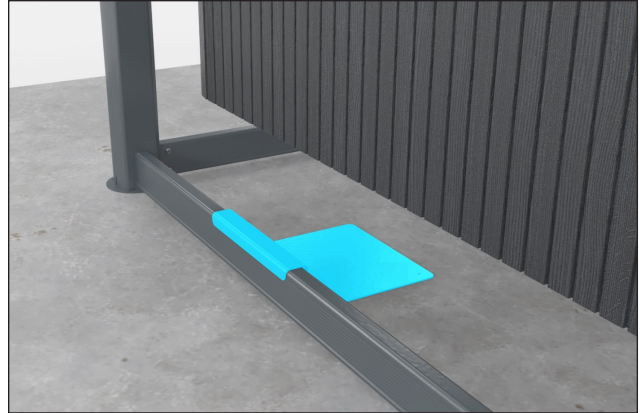

KEY SWITCH INSTALLATION

⚠ DANGER

- The key switch must be:
Permanently mounted 5 ft away from the spa and 5 ft above the deck or ground level.
Vertically mounted in a location where no water downpour or debris could fall on it.
- Failure to properly install the key switch according to these instructions could result in injury or even death.

⚠ WARNING



WHEN OPERATING THE COVER, THE USER MUST ALWAYS HAVE A CLEAR VIEW OF THE COVER AND ITS SURROUNDINGS.

FIGURE 51: FASTEN BACKPLATE OF KEY SWITCH WITH FOUR SCREWS (NOT INCLUDED)

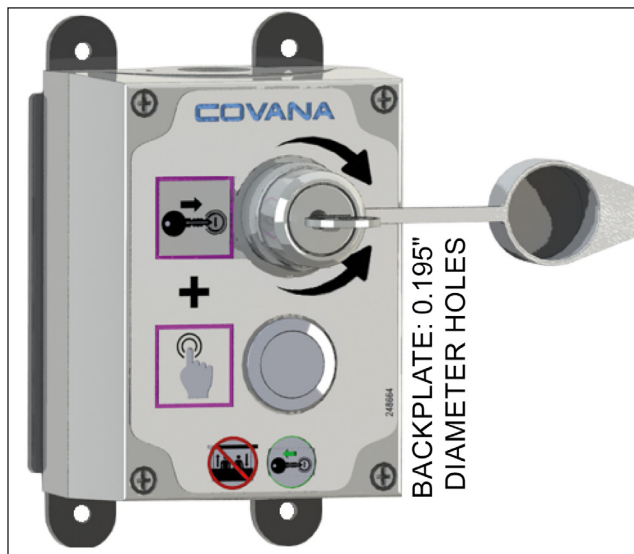

FIGURE 52: OR FASTEN BACKPLATE OF KEY SWITCH WITH TWO SCREWS (NOT INCLUDED)



NON-PERMANENT MOUNTING PLATES (OPTIONAL)

NOTE

This setup is only available for spa base sizes larger than 82" wide for standard COVANA units.



WARNING

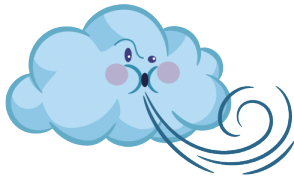

THE PLATES CAN ONLY BE USED IN AREAS WITH LOW WINDS; <30 MPH (50 KM/H) IN OPEN POSITION.



CAUTION



3 INSTALLERS ARE REQUIRED TO INSTALL THE NON-PERMANENT MOUNTING PLATES.

- Raise the cover to slightly lift the spa.
- Two installers must lift the spa at one end, 4" off the ground, while the third installer slips the mounting plate under the spa and hooks it over the U-frame. Two plates must be installed on each side.

FIGURE 53: INSTALL PLATES AS CLOSE AS POSSIBLE TO THE CORNERS

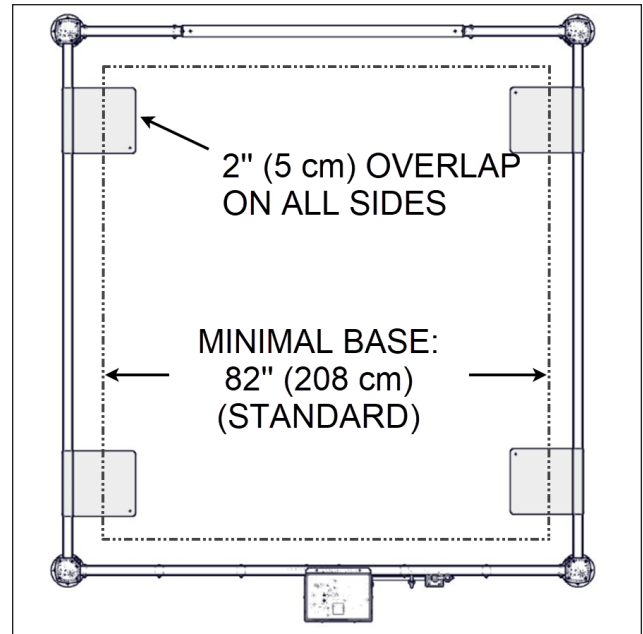
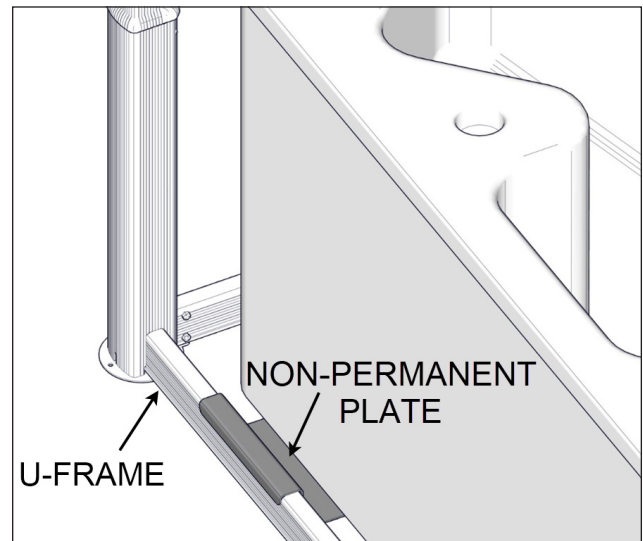

FIGURE 54: HOOK THE PLATES OVER THE U-FRAMES



SEAL INSTALLATION

CAUTION



THE RECOMMENDED TOOL TO INSTALL THE SEAL IS A J-ROLLER WITH RUBBER ROLLER. IT MUST BE FREE OF SCRATCHES, CLEAN AND NON-ABRASIVE.
COVANA PART NO. 239693 (NOT INCLUDED)

CAUTION

- A path at least 1" (2.5 cm) wide all around the perimeter of the spa is necessary to install the seal.
- Install the seal when the ambient temperature is above 50 °F (10 °C).
- Reduce the water vapor steam generated by the spa (turn off the recirculation pump and set the temperature of the water between 2° and 5° under the ambient temperature). Wait for the water to reach the ambient temperature.

FIGURE 55: REMOVE FOAM SPACERS AND TAPE

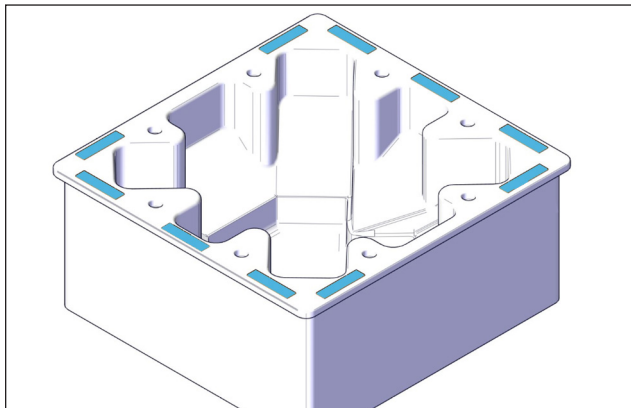

FIGURE 56: DRY TOP OF SPA AND UNDERSIDE OF COVER

CAUTION



THE TOP EDGES OF THE SPA MUST BE 100% DRY AND CLEAN. IF NECESSARY, USE ISOPROPYL ALCOHOL (IPA).

FIGURE 57: APPLY MASKING TAPE CLOSE TO INTERIOR EDGE OF SPA, ON A FLAT SURFACE

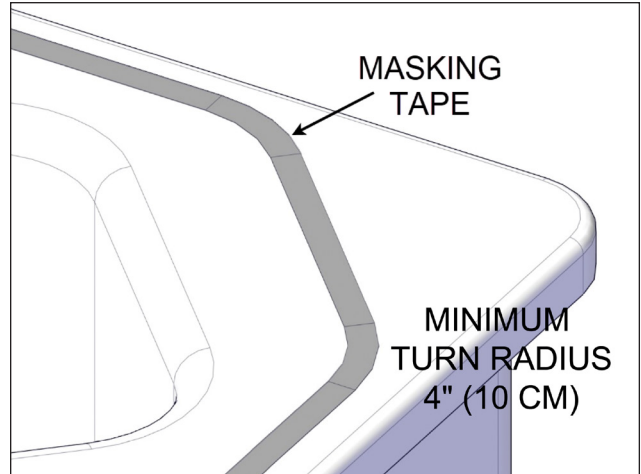
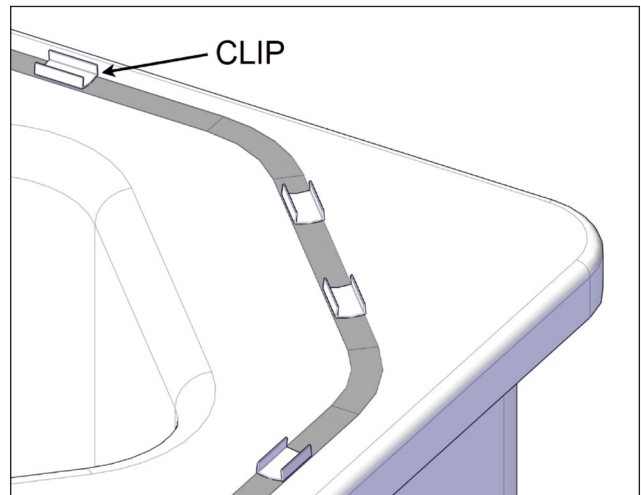

FIGURE 58: DISTRIBUTE THE CLIPS AROUND THE SPA (USE 2 FOR THE JOINT ON THE OPPOSITE SIDE FROM THE SPA ENTRANCE). ONCE THE DISTRIBUTION IS DONE, STICK THEM IN PLACE



CAUTION

Do not install the seal joint near a control system or critical components of the spa.

FIGURE 59: INSTALL SEAL IN CLIPS WITH ADHESIVE LAYER FACING UP

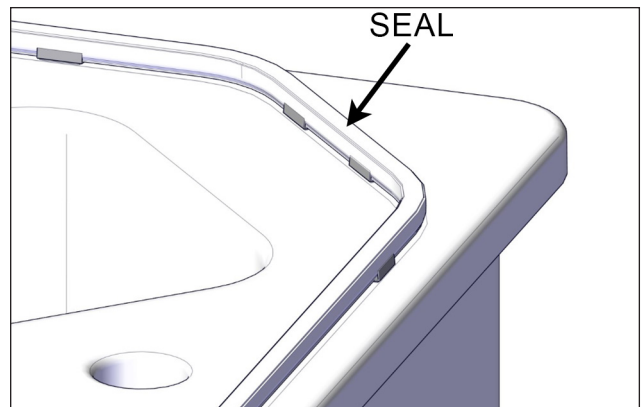
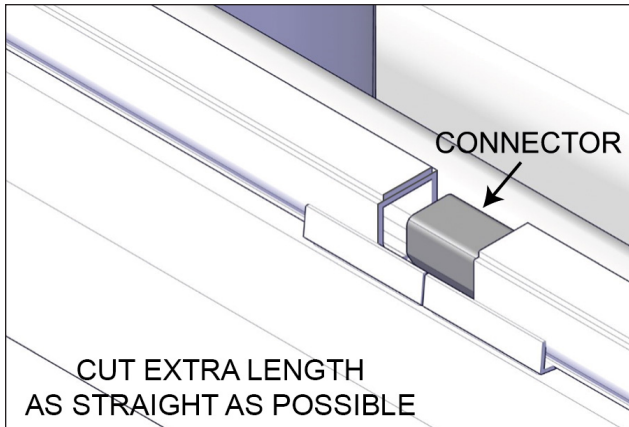

FIGURE 60: INSERT CONNECTOR IN BOTH ENDS OF THE SEAL



⚠ WARNING

- If there is no water in the spa and the ambient air temperature is below 50 °F (10 °C), a heater must be installed **on a pedestal** inside the spa.
- Do not directly heat the acrylic or the seal, as this may cause permanent damage.
- Once the heater is in the spa, lower the cover until it touches the seal. Regularly check the interior air temperature and do not let it reach temperatures above 104 °F (40 °C). After 10 to 15 minutes, remove the heater.
- Make sure that the air temperature in the spa is still between 68 °F and 104 °F (20 °C and 40 °C) before proceeding to the next steps.

FIGURE 61: LOWER THE COVER 1/4" OVER THE SEAL TO TEST THE SEAL PLACEMENT



FIGURE 62: REMOVE RED BACKING OFF SEAL

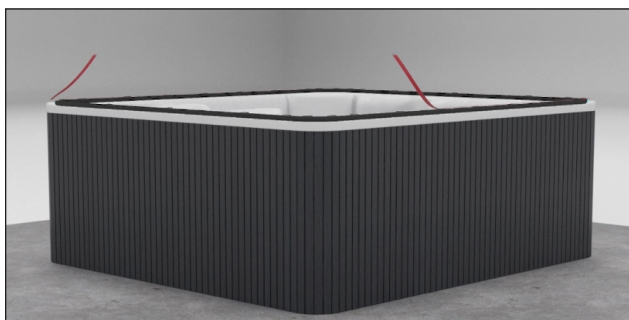

FIGURE 63: COMPLETELY LOWER THE COVER FOR AT LEAST 5 MINUTES

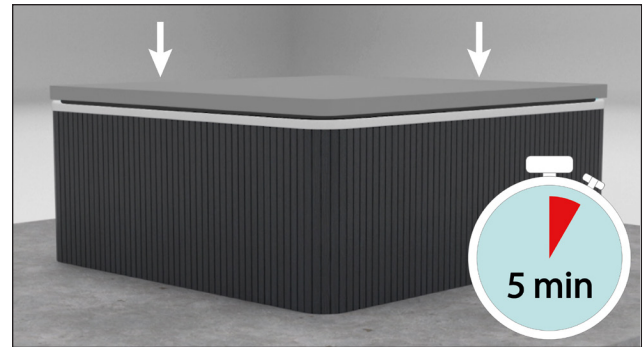

FIGURE 64: RAISE THE COVER 1/4" TO RELEASE THE SEAL FROM THE CLIPS

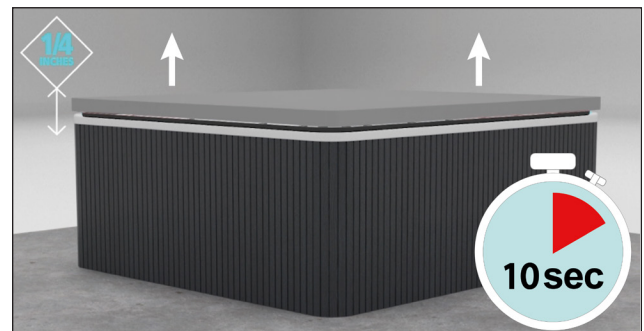

FIGURE 65: WHEN THE SEAL IS RELEASED, RAISE THE COVER 36" ABOVE THE SPA



FIGURE 66: APPLY 15 PSI PRESSURE WITH J-ROLLER

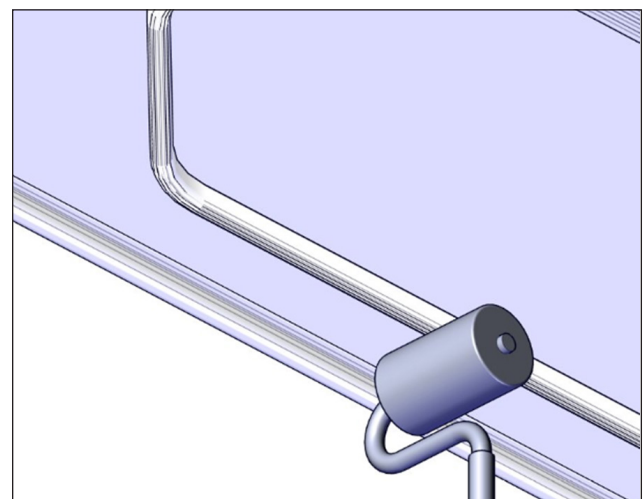

FIGURE 67: REMOVE THE CLIPS AND TAPE

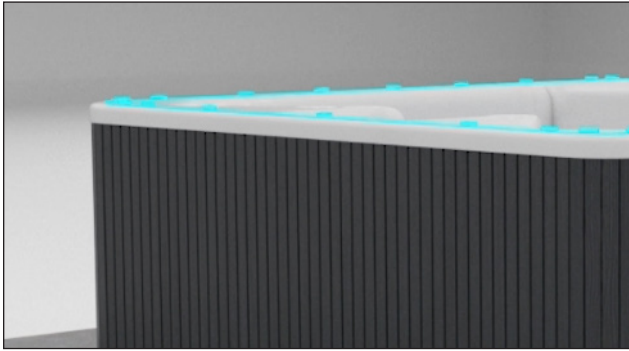

FIGURE 68: LOWER THE COVER 6" ABOVE THE SPA TO ENSURE THE CORNERS ARE AT THE SAME HEIGHT



FIGURE 69: LOWER THE COVER AND CHECK IF THE SEAL IS TOUCHING ALL AROUND THE SPA

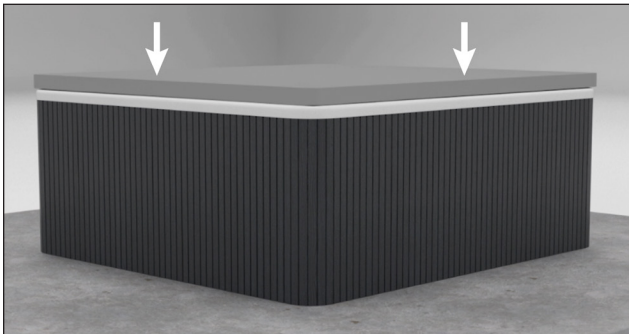

FIGURE 70: LEAVE THE COVER COMPLETELY CLOSED FOR AT LEAST 24 HOURS

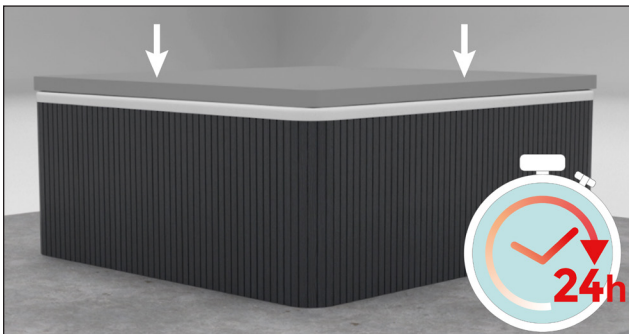

FIGURE 71: WRITE THE DATE OF INSTALLATION ON THE OPERATOR LABEL

COVANA a Division of CANIMEX Group

TOLL FREE # 877-278-8010 PATENTED

MODEL SER.# Y Y M M S S S S

INPUT AMPS / AMPS MAX

MFG. DATE Y Y Y Y - M M M - D D

IN COMPLIANCE WITH UL2452 **UL US LISTED** 42CW SPA COVER OPERATOR

www.covana.com www.canimex.com

DATE OF INSTALLATION:

Fabrique au Canada Made in Canada

FIGURE 72: WRITE THE ADDRESS IN THE IMPORTER BOX (EUROPEAN MODEL SOLD IN SWITZERLAND)

COVANA Division of CANIMEX Group

285 RUE SAINT-GEORGES, DRUMMONDVILLE, QC CANADA J2C 4H3 TOLL FREE # 877-278-8010 WWW.COVARNA.COM PATENTED

Fabrique au Canada Made in Canada

MODEL OASIS, EVO SER.# Y Y M M S S S S

TYPE REFERENCE GHSC MFG. DATE Y Y M M S S S S

DESIGNATION DRIVE FOR VERTICALLY MOVING SPA COVER CONTROLLED BY BIASED-OFF SWITCH

CONTROL CIRCUIT 230 VAC RATED VALUES 1 PH 230 VAC 2.6 A 50 Hz 68 N.m/s 375 WATT IP44

EU IMPORTER

DATE OF INSTALLATION:



  

FIGURE 73: ATTACH THE YELLOW TAG TO THE COVANA KEY RING



- Complete the Customer's installation checklist as well as the Installer's installation checklist.

ELECTRICAL CONNECTIONS

GROUNDING AND POWER SUPPLY CONNECTIONS

- Remove the 4 screws on the bottom side of the operator cover and remove the cover (Figure 73).
- For the complete wiring diagrams refer to the ELECTRICAL DIAGRAMS section.

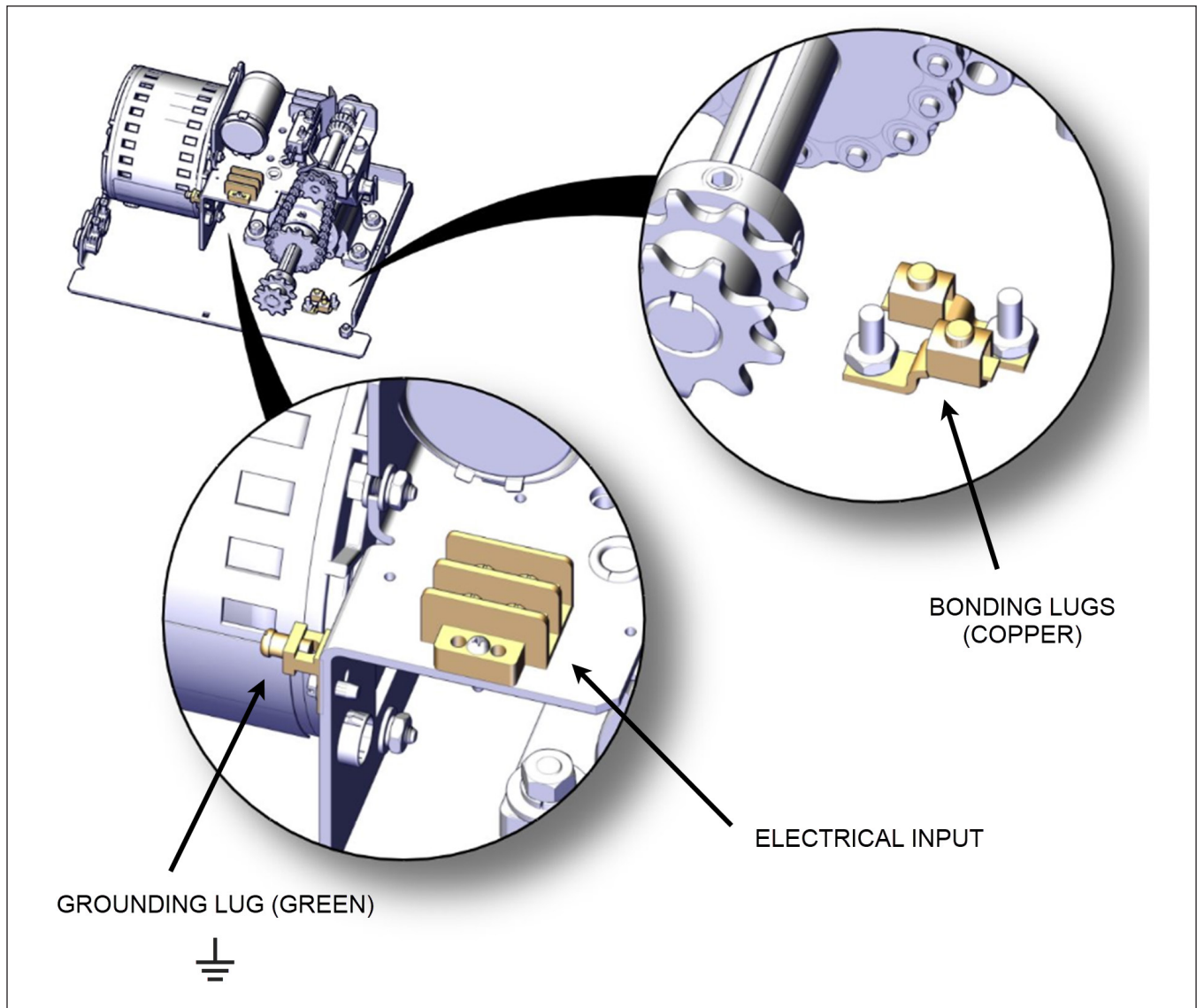

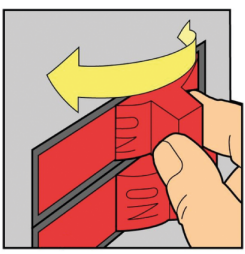

FIGURE 74: POWER SUPPLY CONNECTIONS

LIMIT SWITCH ADJUSTMENT



WARNING



DISCONNECT OR TURN OFF POWER SUPPLY BEFORE STARTING ANY WORK ON THE COVER. ALL ELECTRICAL WORK SHOULD BE PERFORMED BY A QUALIFIED ELECTRICIAN.



WARNING

Both limit switches have been factory-adjusted. If adjustments are required to ensure the cover does not come in contact with surrounding obstacles, the maximum height may be reduced. **Never change the factory setting of the lower limit nor increase the upper limit beyond the factory setting.**

FIGURE 75: REMOVE OPERATOR COVER

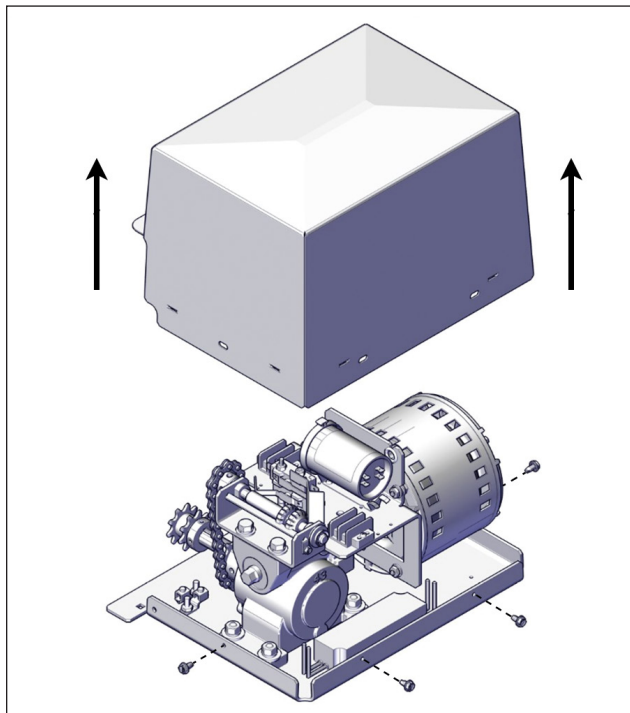
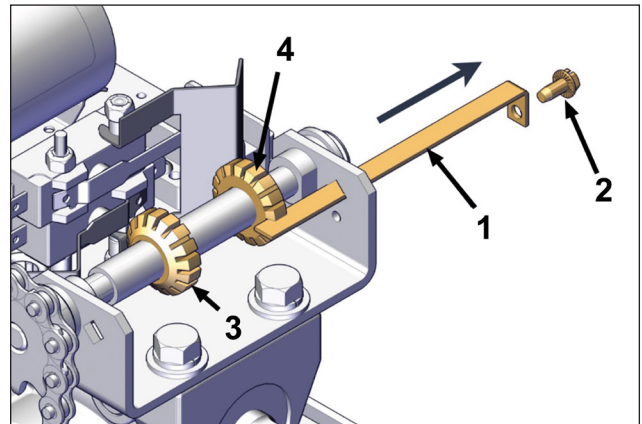

FIGURE 76: REMOVE SLOTTED SCREW AND CAM PLATE



1	CAM PLATE	3	DOWN-CAM WHEEL
2	SLOTTED SCREW	4	UP-CAM WHEEL

- To reduce the upper limit, turn the up-cam wheel. Removing a tooth is equivalent to removing 5/32" (4 mm) on the cover lifting stroke.

FIGURE 77: TURN UP-CAM WHEEL

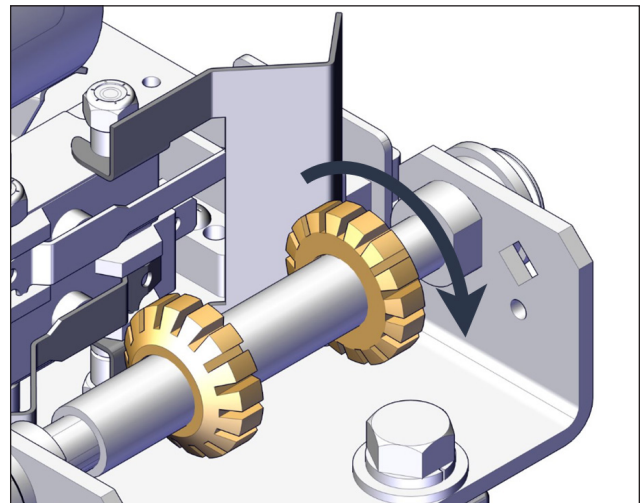

Once the upper limit is set:

1. Reinstall the cam plate (make sure it is inserted in the slot of each cam wheel).
2. Reinsert the slotted screw.
3. Reinstall the operator cover (without the four screws).



WARNING

Never operate the cover without the cam plate and retaining screw installed.

- Turn the power on and test the height of the cover. Repeat the previous steps if necessary.
- Once the adjustment is completed, fasten the operator cover with the four screws.

SPA COVER INSTALLATION Checklist

☑ INSTALLATION STEPS	NOTES
☐ The base preparation steps are done correctly.	
☐ The installation steps are done correctly.	
☐ The seal is properly installed and there is no steam leaking out around the cover.	
☐ The key switch is permanently installed vertically, at least 5 ft (1.5 m) away from the spa and 5 ft (1.5 m) from the ground.	
☐ The electrical portion of the installation was done by a certified electrician.	
☐ All parts supplied and included into the crate are installed.	
☐ The start-up procedure is completed.	
☐ The four jacks have been properly anchored to the foundation OR a set of non-permanent mounting plates has been installed.	
☐ The all-weather seals work properly.	
☐ The middle sleeves slide freely (manually slide the middle sleeves up and down when the cover is half open).	
☐ The date of installation has been written on the technical specifications label.	
☐ The yellow tag is attached to the COVANA key ring.	

Serial number	
Installation date (YYYY/MM/DD)	
Installer's name	
Installer's signature	
Customer's name	
Customer's signature	
Customer's address	
Retailer's name	

CUSTOMER COPY

SPA COVER INSTALLATION

Checklist

<input checked="" type="checkbox"/> INSTALLATION STEPS	NOTES
<input type="checkbox"/> The base preparation steps are done correctly.	
<input type="checkbox"/> The installation steps are done correctly.	
<input type="checkbox"/> The seal is properly installed and there is no steam leaking out around the cover.	
<input type="checkbox"/> The key switch is permanently installed vertically, at least 5 ft (1.5 m) away from the spa and 5 ft (1.5 m) from the ground.	
<input type="checkbox"/> The electrical portion of the installation was done by a certified electrician.	
<input type="checkbox"/> All parts supplied and included into the crate are installed.	
<input type="checkbox"/> The start-up procedure is completed.	
<input type="checkbox"/> The four jacks have been properly anchored to the foundation OR a set of non-permanent mounting plates has been installed.	
<input type="checkbox"/> The all-weather seals work properly.	
<input type="checkbox"/> The middle sleeves slide freely (manually slide the middle sleeves up and down when the cover is half open).	
<input type="checkbox"/> The date of installation has been written on the technical specifications label.	
<input type="checkbox"/> The yellow tag is attached to the COVANA key ring.	

Serial number	
Installation date (YYYY/MM/DD)	
Installer's name	
Installer's signature	
Customer's name	
Customer's signature	
Customer's address	
Retailer's name	

INSTALLER COPY

OWNER'S MANUAL

OPERATE THE COVER



WARNING



READ THE SAFETY SECTION OF THIS MANUAL CAREFULLY BEFORE OPERATING THE COVER.

RAISING/LOWERING THE COVER WITH THE KEY SWITCH



WARNING

Ensure that:

- There is nobody in or near the spa.
 - There is no obstruction over or around the cover.
 - The cover is completely visible when operating the key switch.
 - The key is removed from the key switch when not in use; Bring the key in the spa to prevent any unauthorized operation of the cover.
-
- To raise the cover, press **and** hold the button while turning the key UP (↑ arrow).
 - To lower the cover, press **and** hold the button while turning the key DOWN (↓ arrow).
 - Remove the key and install the rubber cap back on the key switch after each use.

NOTE

The cover will automatically stop in both the fully open and fully closed position.

IMPORTANT NOTE

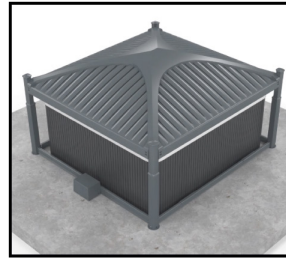

KEEP THE COVER FULLY CLOSED WHEN NOT IN USE.



CAUTION



REMOVE ALL DEBRIS AND SNOW FROM THE COVER, AROUND THE SLEEVES AND FROM THE MOTOR SIDE.

LED LIGHTS

To operate the lighting system, press the push button located under the cover.

The lighting system operates in 2 different modes:

- Color locked
- Color wheel

FIGURE 78: SWITCH LIGHTS OFF AND IMMEDIATELY BACK ON TO SELECT MODE

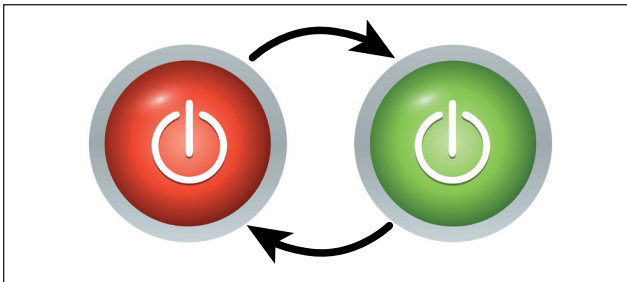

IMPORTANT NOTE

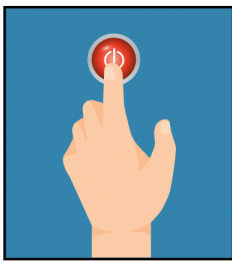

**ALWAYS TURN
THE LIGHTS OFF
WHEN NOT IN USE.**

MANUAL OPERATION OF THE COVER

 **WARNING**

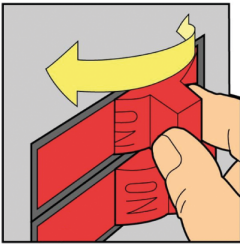

DISCONNECT OR TURN OFF POWER SUPPLY BEFORE STARTING ANY WORK ON THE COVER. ALL ELECTRICAL WORK SHOULD BE PERFORMED BY A QUALIFIED ELECTRICIAN.

FIGURE 79: REMOVE OPERATOR COVER

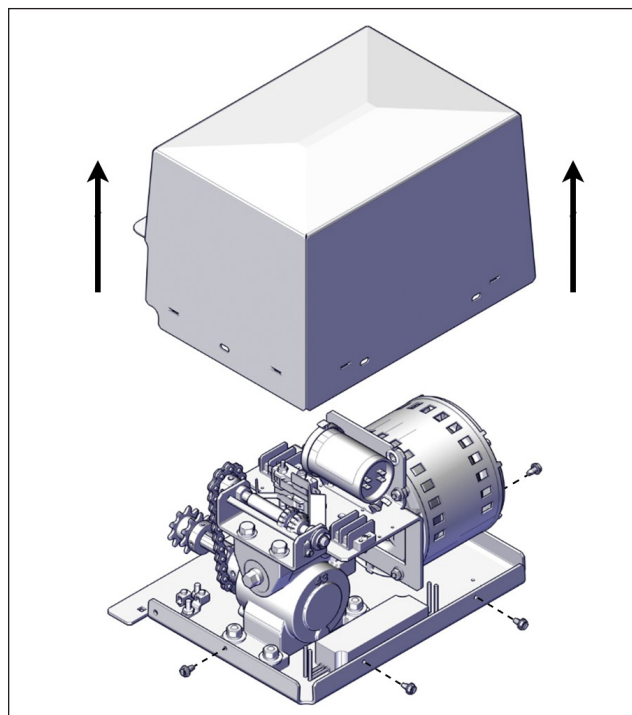

- Slowly turn the extension shaft clockwise to lower the cover, or counterclockwise to raise it. Stop immediately if any tension occurs.

 **WARNING**

Do not exceed the limits of the mechanism. Failure to respect this guideline may cause mechanical failure.

FIGURE 80: USE WRENCH TO TURN EXTENSION SHAFT

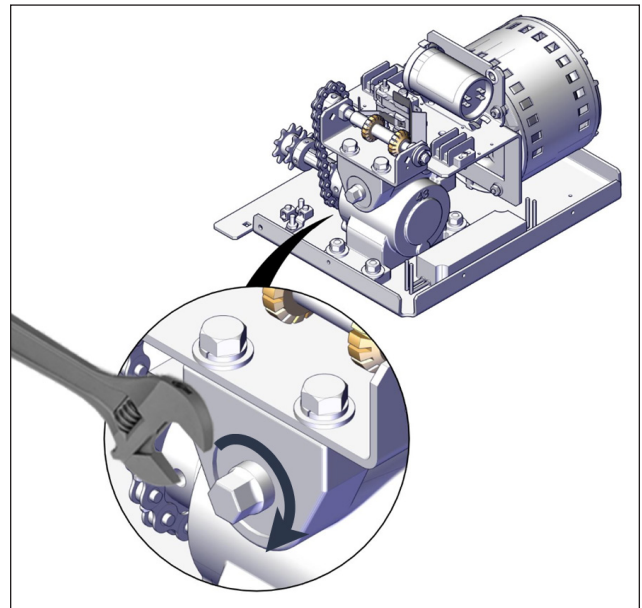

- Reinstall the operator cover with the four screws.
- Reconnect and turn on the power supply.

WIRE GUARD REASSEMBLY

Reassemble the wire guard harness if the magnetic plate came off to let the wire out.

FIGURE 81: CHECK IF WIRE HAS BEEN DAMAGED

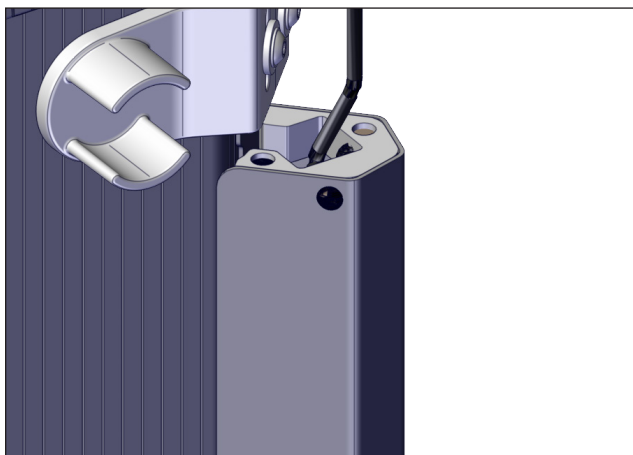
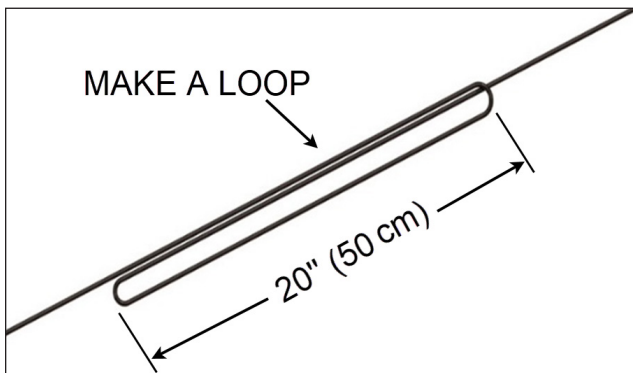

FIGURE 82: FOLD WIRE IN TWO TO CREATE A 20" LOOP



WARNING

- Do not tape or fix the wire together.
- Ensure the wire is not caught in the post or twisted around any object before proceeding.

FIGURE 83: THREAD LOOP IN WIRE GUARD

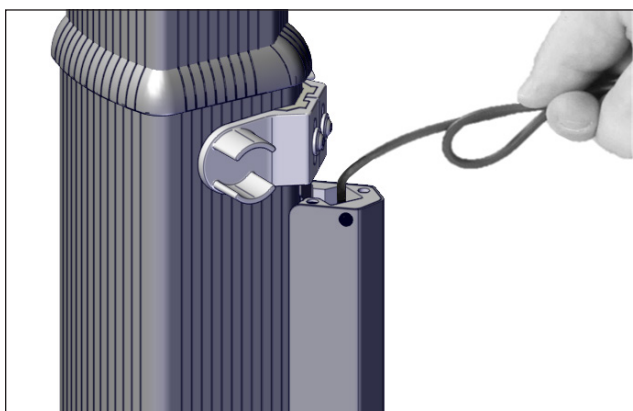

- Reinstall the plate on top of the wire guard. The wire should have sufficient tension and look straight.

FIGURE 84: FINAL ASSEMBLY SHOULD LOOK LIKE THIS

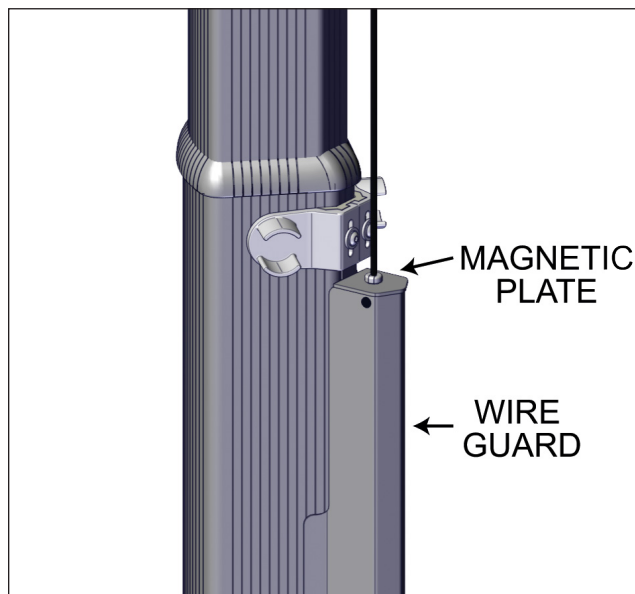

- Operate the cover by cycling it up and down. If the plate still comes off due to excessive tension, consult the TROUBLESHOOTING section or call your local Covana retailer.

ELECTRICAL DIAGRAMS

ELECTRICAL DIAGRAMS

WIRING DIAGRAM (NORTH AMERICA) (LIGHTS) – 60 HZ, 120 VAC OPERATOR

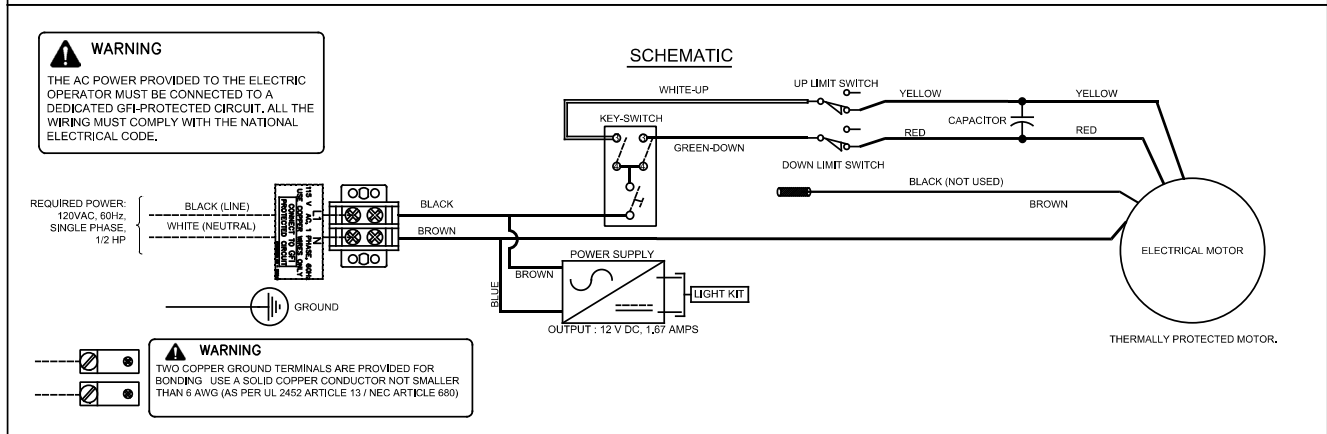
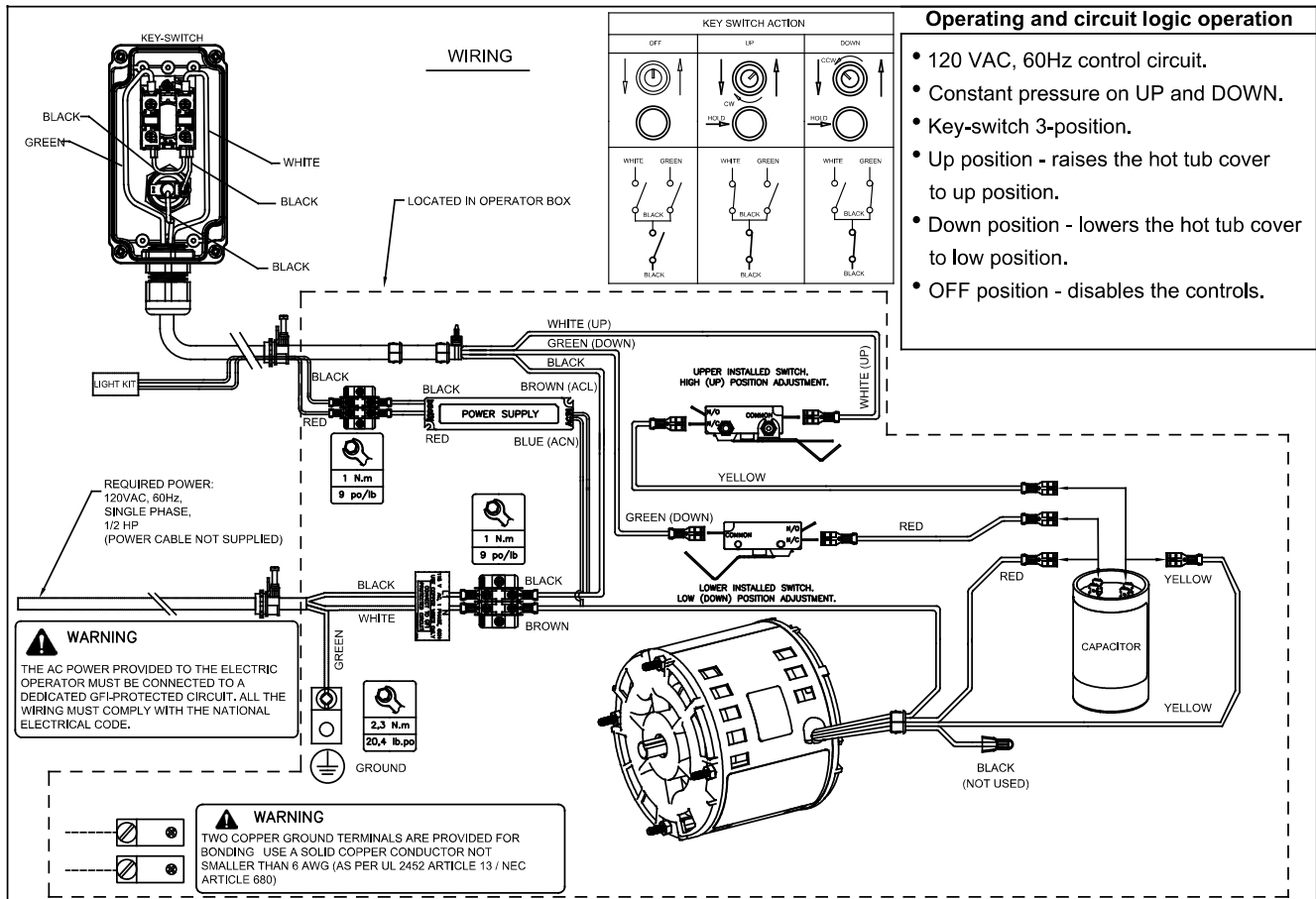

Note: The spa cover operator is designed with an instant reverse single-phase motor with internal automatic reset thermal overload. In case of over-use, the motor will overheat and will shutdown. Once the motor cools down to its operational temperature, the spa cover could be used again.

The control circuit operates at 120VAC, 60Hz. Due to the resistance in the wire used to carry the control circuit voltage, it is important to use the appropriate wire size between the operator and the main power supply. If wire gage is not suitable for the distance, problems in operator will be encountered such as motor humming, premature wear of the limit switches' contacts and possible tripping of the motor's thermal protection. All power wiring should be installed by a qualified electrician and may vary with respect to conduit size and type as specified in the National Electric Code (NEC), Article 430, allowing 5% volt drop, or comply to any other local codes and regulations. Power must be connected in accordance with local electricity codes.

WIRING DIAGRAM (EUROPE) (LIGHTS) – 50 HZ, 230 VAC OPERATOR

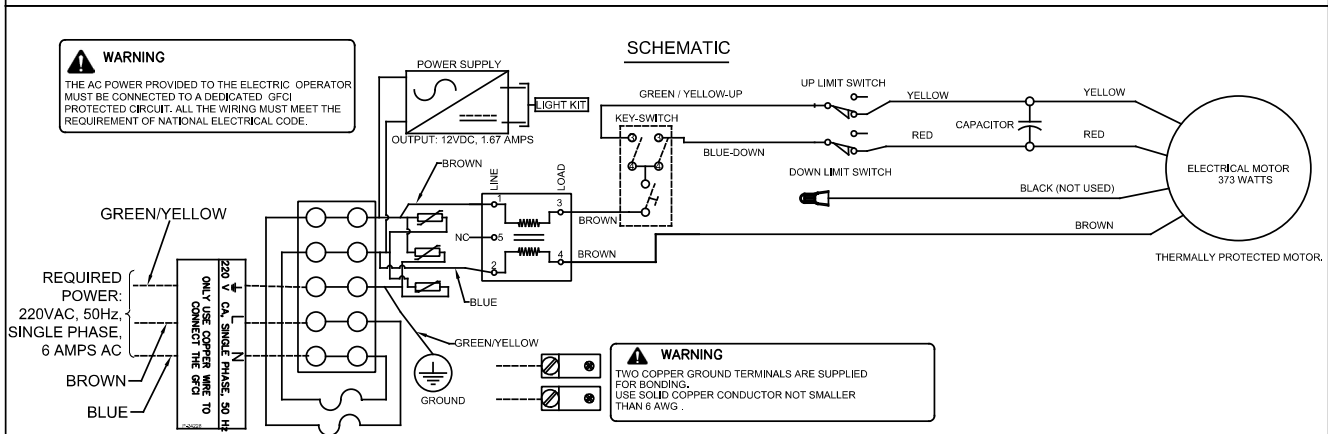
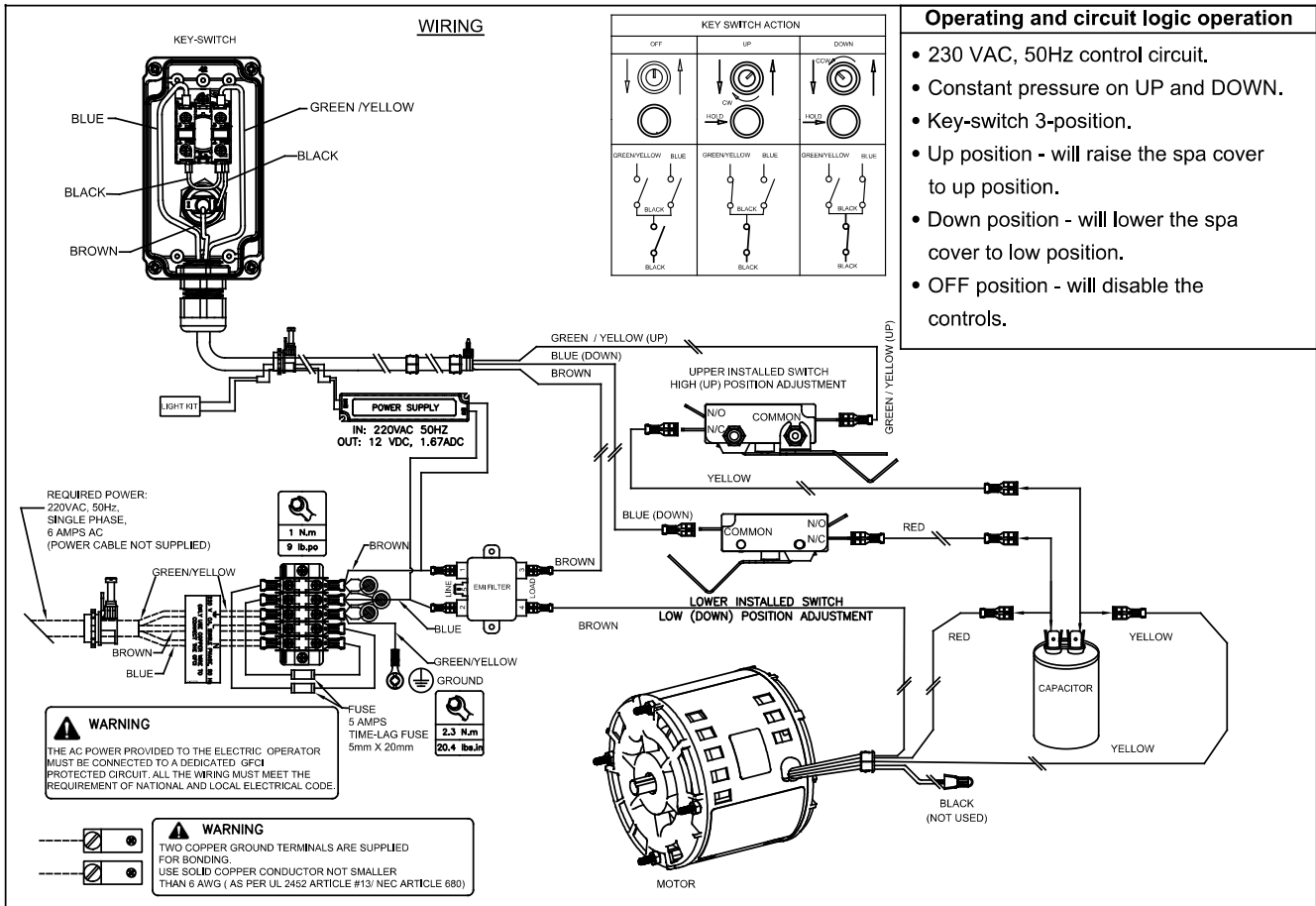

Note: The spa cover operator is designed with an instant reverse single-phase motor with internal automatic reset thermal overload. In case of over-use, the motor will overheat and will shutdown. Once the motor cools down to its operational temperature, the spa cover could be used again.

The control circuit operates at 230 VAC, 50Hz. Due to the resistance in the wire used to carry the control circuit voltage, it is important to use the appropriate wire size between the operator and the main power supply. If wire gage is not suitable for the distance, problems in operator will be encountered such as motor humming, premature wear of the limit switches' contacts and possible tripping of the motor's thermal protection. All power wiring should be installed by a qualified electrician and may vary with respect to conduit size and type as specified in the National Electric Code (NEC), Article 430, allowing 5% volt drop, or comply to any other local codes and regulations. Power must be connected in accordance with local electricity codes.

MAINTENANCE

MAINTENANCE

WASHING THE COVER

 **CAUTION**

NEVER USE:

- A PRESSURE WASHER OR HIGH PRESSURE
- HARSH DETERGENTS
- ABRASIVE CLEANERS
- CLEANER OR STAIN REMOVER WITH CHLORINATED OR AROMATIC HYDROCARBONS



Step 1.

Gather supplies

- 1% solution of household dish soap (must have a neutral 6.5-7.5 pH range)
- Soft plastic brush
- Sponge
- Cloth



Step 2.

Wash the cover

1. Rinse the cover to remove any large debris.
2. Apply the soap solution in a scrubbing or circular motion using a sponge, cloth or soft plastic brush. 
3. Quickly rinse very thoroughly to remove all traces of soap; otherwise, a film will build up giving the cover a dull, dirty appearance.

WINTERIZING

 **CAUTION**

 FOLLOW THESE INSTRUCTIONS IF YOU PLAN TO STOP USING THE SPA FOR A LONG PERIOD OF TIME OR IF THE TEMPERATURE DROPS BELOW FREEZING POINT.

Step 1.

Prepare the spa for closure

Follow the spa manufacturer's winterization instructions.

Step 2.

Prepare the cover for closure

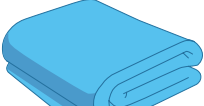
1. Remove dust, greasy residue and dirt from the cover.
2. Close the cover.
3. Turn off and secure the power supply of the cover.
4. Place a waterproof tarp on the cover, and another on the control box. 

 **CAUTION**

Use a tarp only for the winterization procedure and during the cold season; remove it as soon as seasonal temperatures are higher than the freezing point.

 **CAUTION**

 REMOVE SNOW REGULARLY OR AFTER HEAVY SNOWFALL. DO NOT LET MORE THAN 12" (30 CM) OF SNOW ACCUMULATE ON THE COVER.

POST GREASING

The internal jacks require yearly greasing to ensure the best performance. Early in the fall season is the best time.

IMPORTANT NOTE



WHITE LITHIUM GREASE IS RECOMMENDED FOR ALL CLIMATES. IDEALLY A SPRAYABLE GREASE OR AN EQUIVALENT LOW TEMPERATURE SYNTHETIC GREASE.

NOTE

The posts will not lift by removing the top plates. Only the motor can raise or lower the posts.

POST GREASING PROCEDURE

- Lower the cover until it is fully closed.

FIGURE 85: REMOVE THE RUBBER CAP FROM EACH POST

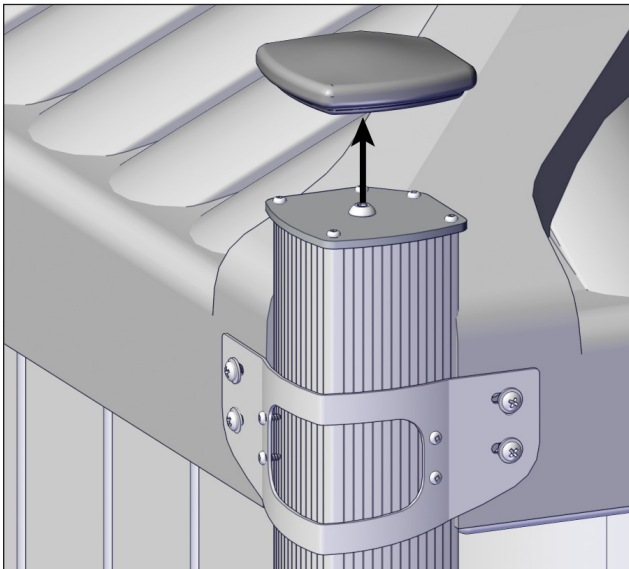
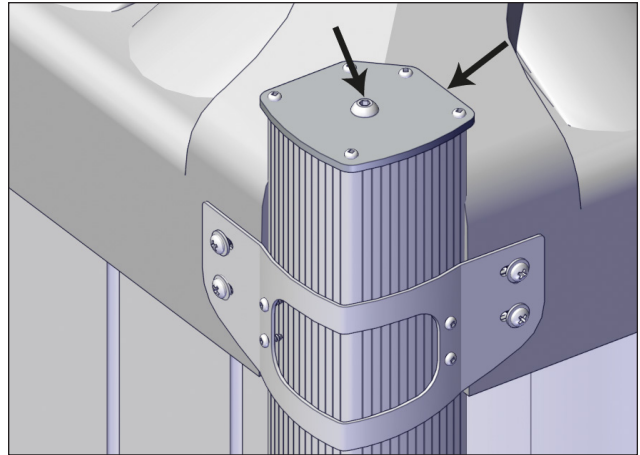

FIGURE 86: REMOVE THE TOP PLATE FROM EACH POST (6 SCREWS AND 1 BUSHING)



WARNING

Failure to remove all four top plates will result in important damages to the cover.

FIGURE 87: RAISE THE JACKS ALL THE WAY UP WITH THE KEY SWITCH

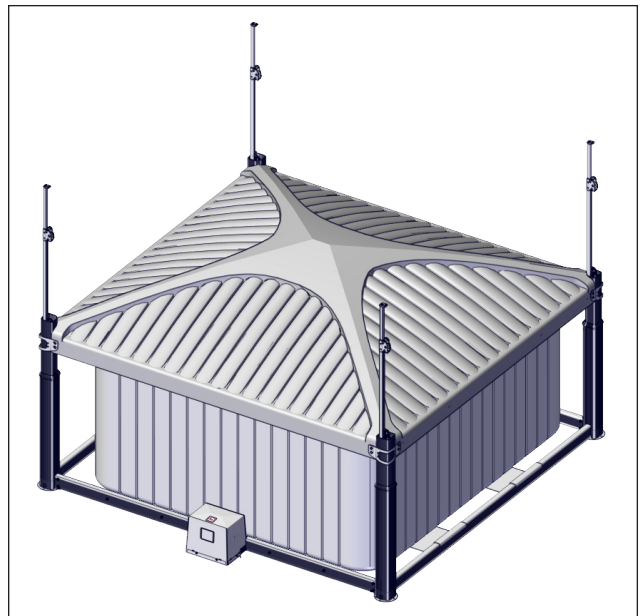

FIGURE 88: SPRAY GREASE ON THE SLIDING PARTS AND MECHANICAL COMPONENTS OF EACH JACK

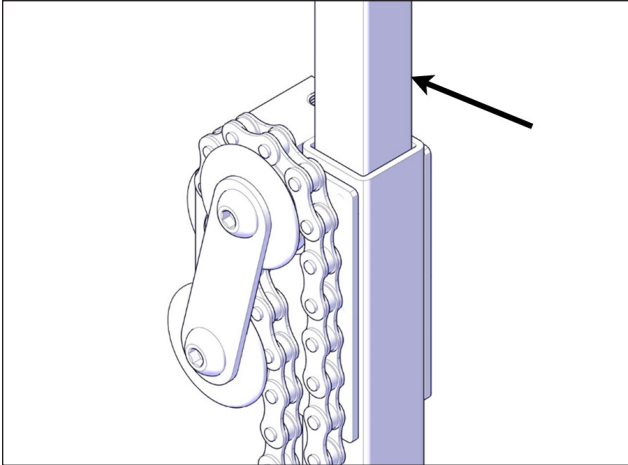
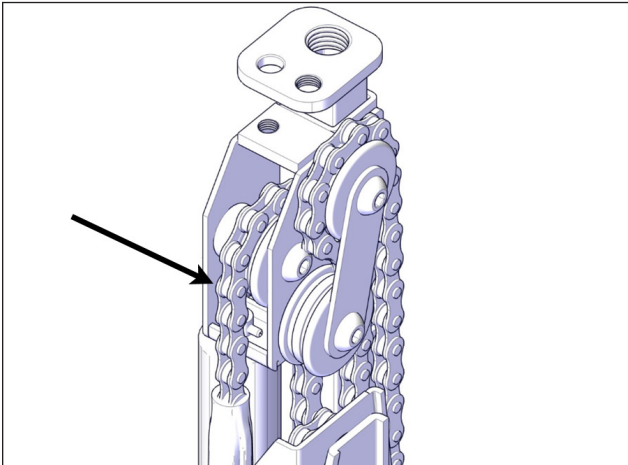

FIGURE 89: INSPECT THE CHAINS FOR SIGNS OF DETERIORATION



- Cycle the system up and down and check if more grease should be added.
- Lower the system completely until it stops automatically.
- Reinstall the top plate on each post with the five screws, as well as the hexagonal head screw and bushing.
- Reinstall the rubber cap on top of each post.

CHAIN LUBRICATION

The transmission power chains attached to the operator require yearly greasing.

IMPORTANT NOTE



WHITE LITHIUM GREASE IS RECOMMENDED FOR ALL CLIMATES. IDEALLY A SPRAYABLE GREASE OR AN EQUIVALENT LOW TEMPERATURE SYNTHETIC GREASE.

FIGURE 90: TWO CHAINS ARE ATTACHED TO THE OPERATOR (LEFT AND RIGHT)

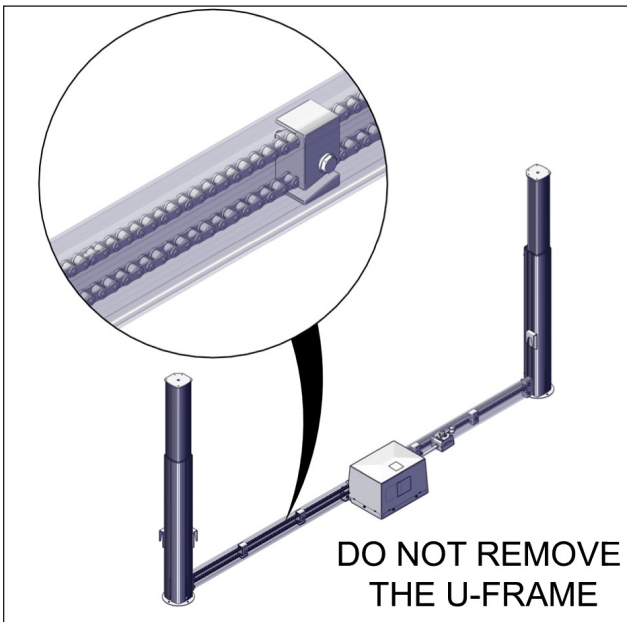

FIGURE 91: PARTIALLY UNSCREW THE SCREW AT THE BASE OF THE EXTERNAL SLEEVE

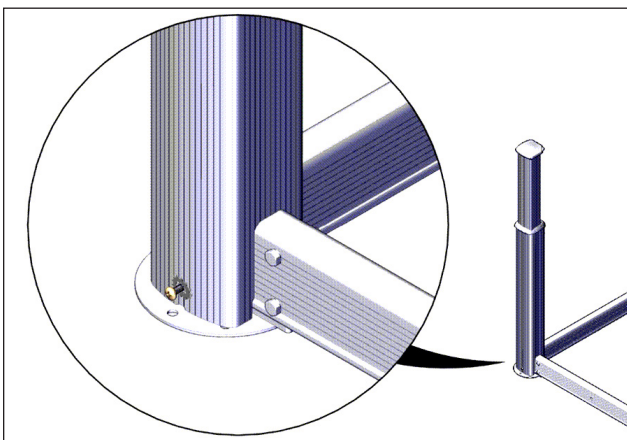
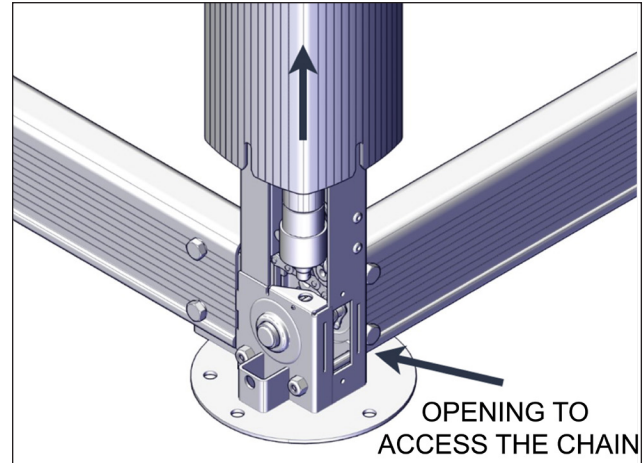

FIGURE 92: MANUALLY RAISE THE SLEEVE AND KEEP IT UP WITH A WOODEN BLOCK











- Spray the chain lightly with grease while another operator cycles the cover up and down with the key switch.

FIGURE 93: LOWER THE SLEEVE AND TIGHTEN THE SCREW

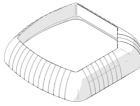

- Repeat previous steps on the opposite post.

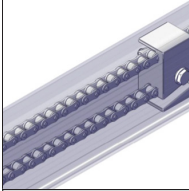
PERIODIC MAINTENANCE SCHEDULE - OASIS

ITEM	TASKS	Each use	Weekly	Every 3 months	Yearly
	<p>COVER</p> <ul style="list-style-type: none"> Wash with a mild detergent (i.e., dishwashing detergent) and water. Rinse well using only water. Remove snow and debris from the cover, around the sleeves and from the motor side. Perform a visual inspection (debris, snow, ice, etc.). Listen to any unusual noises during operation. <p>LIFTING MECHANISM Raise and lower the cover.</p>	As needed			
	<p>SLEEVES Check if correctly positioned (middle sleeves are not out of their normal position).</p>	●			
	<p>ALL-WEATHER SEALS Check if correctly positioned (in contact with outer sleeves when cover is closed).</p>	●			
	<p>ROLLER SHADES Adjust the brackets if needed to prevent wrinkles.</p>		●		
	<p>SEAL Make sure there is no vapor steam leakage.</p>		●		
	<p>ANCHORS Check anchoring of cover.*</p>				●
	<p>CHAINS</p> <ul style="list-style-type: none"> Check tension of each post and in U-frames.* Lubricate chains in each post and in the U-frames.* 				●
	<p>JACKS Grease the jack assemblies.*</p>				●
<p>GFCI</p>	<p>Test GFCI.</p>			●	

*Contact your local Covana retailer.

Call your Covana retailer for any mechanical, electrical or aesthetic maintenance.

TECHNICAL SPECIFICATIONS

TECHNICAL SPECIFICATIONS

COVER FRONT VIEW

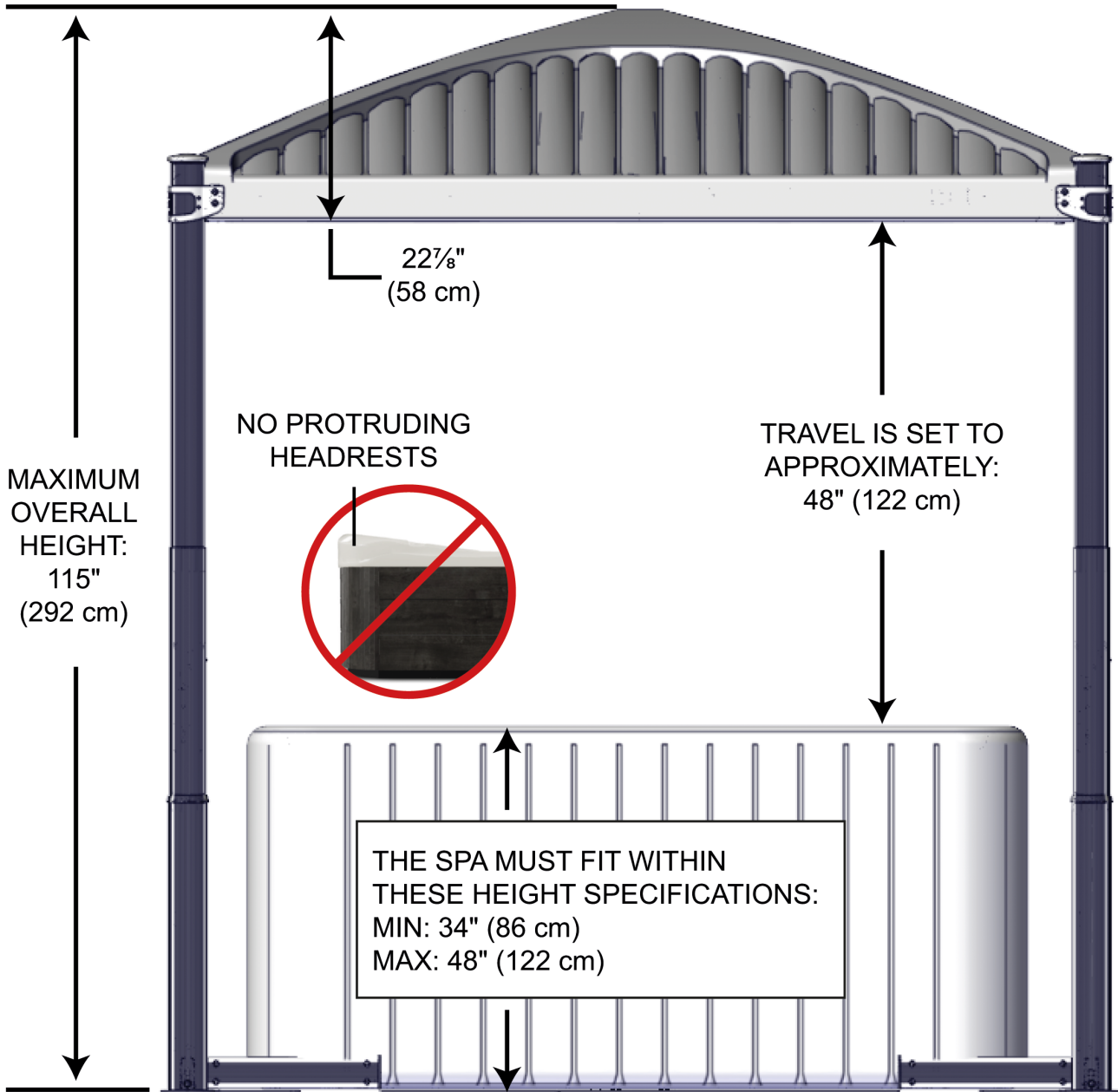

FRAME DIMENSIONS AND FOOT PRINT

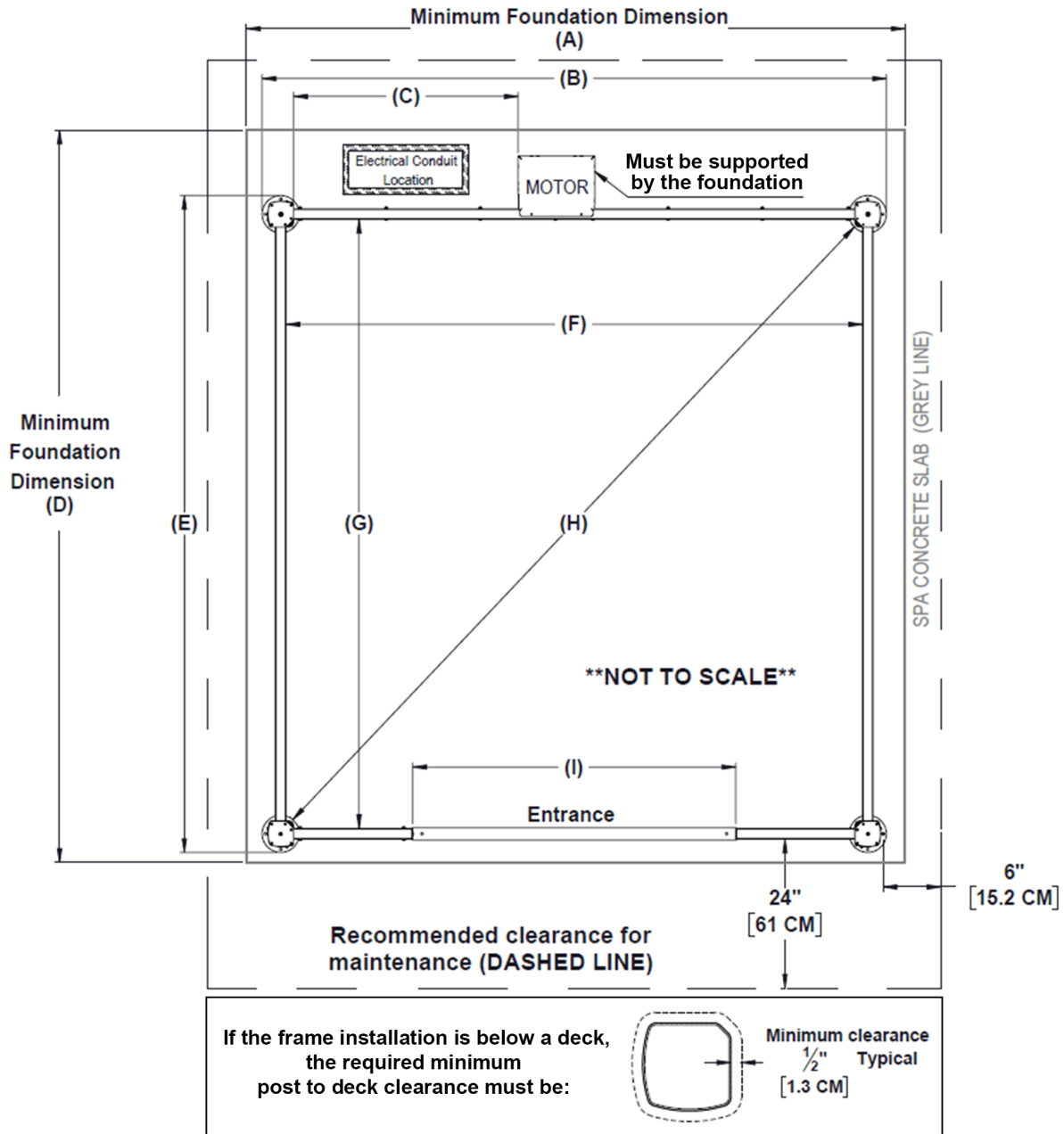

INCH (mm)	A	B	C	D	E	F	G	H	I
STANDARD MODEL	106 (2692)	100.5 (2553)	36.1 (917)	118 (2997)	105.75 (2686)	93 (2362)	98 (2489)	130.75 (3321)	52 (1321)

CONCRETE SLAB LAYOUT OPTION

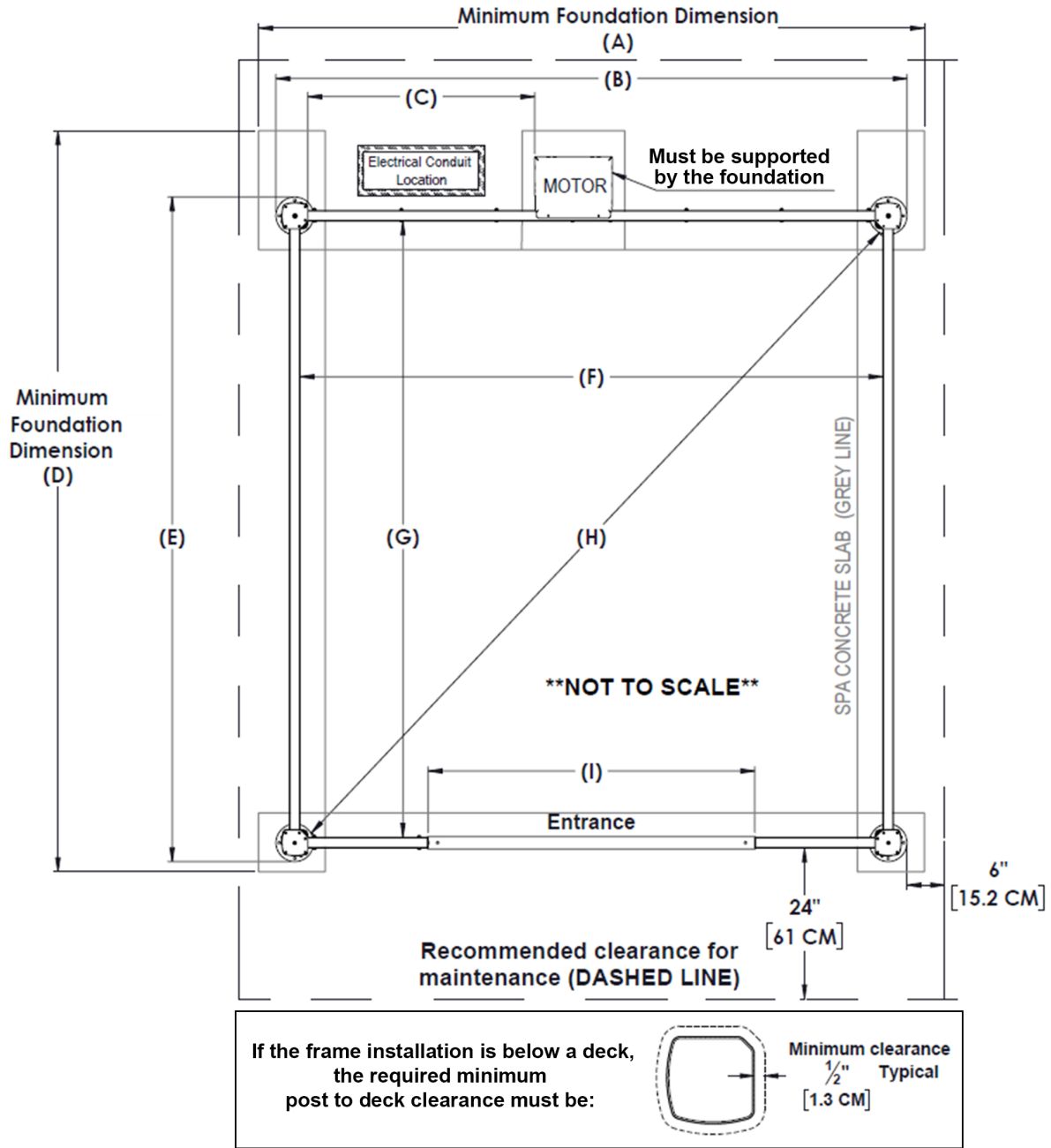

INCH (mm)	A	B	C	D	E	F	G	H	I
STANDARD MODEL	106 (2692)	100.5 (2553)	36.1 (917)	118 (2997)	105.75 (2686)	93 (2362)	98 (2489)	130.75 (3321)	52 (1321)

ELECTRICAL SPECIFICATIONS

The cover requires a dedicated single phase 115 VAC (North America) or 230 VAC (Europe) hard-wired power supply.

The cover must be installed in accordance with and comply with all applicable local codes and regulations. All wiring and connections should be performed by a certified electrician.

Wires and cables should be sized according to local codes and regulations.

NORTH AMERICAN REQUIREMENTS

Voltage	115 V, 60 Hz (1 hot, 1 neutral, 1 ground)
GFCI	15 A single-pole GFCI (not included)
Current draw	Max 12 A

EUROPEAN REQUIREMENTS

Voltage	230 V, 50 Hz (2, 1 ground)
GFCI	10 A single-pole GFCI (not included)
Current draw	Max 6 A

WARNING

Covana does not allow any modifications to the electrical system. Covana reserves the right to void the warranty if any modification is done without its approval.

OPERATION LIMITATIONS

WARNING

The cover should never be used if the following conditions are reached.

Maximum wind	Gusts of 30 mph (50 km/h) while in the raised position. Lower the cover when winds exceed 30 mph (50 km/h).
Maximum weight on the cover (evenly distributed)	200 lb. (90 kg) Before operating the cover, make sure it is free of any dirt, debris, leaves, snow, etc.

GENERAL SPECIFICATIONS

Lifting speed	2.5 in./s (6.35 cm/s)
Total weight	600 lb. (272 kg)
Length of key switch cable	25 ft (7.6 m)

TROUBLESHOOTING

TROUBLESHOOTING

PROBLEM	PROBABLE CAUSES	SOLUTIONS
The cover does not raise or lower (silent motor and no movement).	The GFCI is tripped.	Reset the GFCI.
	The power source is disconnected.	<ul style="list-style-type: none"> Verify that the power source is enabled. Check the breaker panel. Verify whether the cables were damaged or pinched.
The cover does not raise or lower (motor humming and some visible movement).	Posts are frozen.	Use methanol to free ice buildup on posts.
	Jack assemblies are jammed.	Apply grease on the post assemblies.
	The motor is obstructed.	<ul style="list-style-type: none"> Hold the key in the problematic direction. If the cover moves in the opposite direction, this indicates a mechanical restriction (contact your local authorized Covana retailer). If the cover does not move in the opposite direction, reset the lower limit of the cover.
	Posts are obstructed.	<ul style="list-style-type: none"> Verify whether any posts are obstructed. Verify the relative position of the four posts (see FOUNDATION PREPARATION).
	The debris on the cover is too heavy.	Remove all the debris from the top of the cover.
If all previous attempts failed, contact your local authorized Covana retailer.		
The posts are not equally positioned.	The post screws (attached to the outer shell) are loose.	Lower the cover completely and fasten the post back in at the correct height.
	The chain skipped during operation.	Lower the cover and replace the chain.
	A spring pin at the bottom of a jack is broken.	Replace any missing or broken spring pin by lifting the outer sleeve, using an awl and a hammer.
	A drive shaft has fallen off.	Verify whether a drive shaft has fallen off and if it is the case, reinstall the shaft.
	Excessive weight on one side of the cover.	Remove all debris from the top of the cover.
If all previous attempts failed, contact your local authorized Covana retailer.		
The shades are loose, retracted improperly or disconnected from the brackets. The shades are wrinkling or bulging at the roller.	<ul style="list-style-type: none"> The internal spring is not wound enough. Too much tension in the internal spring. 	<ul style="list-style-type: none"> Consult the Shade installation manual. Remove the bottom rod and reset the tension back to "4 turns".
	Holding brackets are not parallel.	Make sure the outer sleeves are sitting on the foot plate, reposition the holding brackets so the roller shade is moving straight.
The middle sleeve has gripped and might have dropped abruptly.	Posts are frozen.	Verify the position of the all-weather seal. While the cover is closed, it must be sitting on the top of the outer sleeve.
	Sleeves are misaligned.	<ul style="list-style-type: none"> Reinstall the sleeves. Check level on 2 faces of the sleeve.
	The stopper kit is broken/missing.	Check whether the stopper kit is broken/missing.
If all previous attempts failed, contact your local authorized Covana retailer.		

PROBLEM	PROBABLE CAUSES	SOLUTIONS
The cover raises unevenly.	<ul style="list-style-type: none"> • The chain is broken. • A spring pin is broken. • A drive shaft has fallen off. • Posts are gripped. 	Do not operate the cover.
Contact your local authorized Covana retailer for technical support.		
Cover raises but does not lower. ⚠️ Cut power before performing any electrical work.	The cam plate is incorrectly positioned or missing.	Check that the cam plate is installed and in good condition (see LIMIT SWITCH ADJUSTMENT).
	The key switch is faulty.	Contact your local authorized Covana retailer for technical support.
	Limit switches don't operate properly.	<ul style="list-style-type: none"> • Certified electrician only: Open the operator and check for faulty up and down limit switches. • Check if there is any corrosion on the terminals and clean it if necessary. • Check if any electrical cables are damaged or pinched.
Cover lowers but does not raise. ⚠️ Cut power before performing any electrical work.	The cam plate is incorrectly positioned or missing.	Check that the cam plate is installed and in good condition (see LIMIT SWITCH ADJUSTMENT).
	The key switch is faulty.	Contact your local authorized Covana retailer for technical support.
	Limit switches don't operate properly.	<ul style="list-style-type: none"> • Certified electrician only: Open the operator and check for faulty up and down limit switches. • Check if there is any corrosion on the terminals and clean it if necessary. • Check if any electrical cables are damaged or pinched.
Cover seal turned black.	The seal has accumulated mold.	Clean the affected areas with bleach and a soft brush. Rinse well with water.
Lights do not work.	The lighting assembly is faulty.	Check if the power source is enabled.
	The light switch is faulty.	Replace the light switch.
If all previous attempts failed, contact your local authorized Covana retailer.		
Magnetic plate is not holding in place.	Excessive tension in the Constant Tension System (CTS 70).	Lift the side of the outer shell where the cable exits from the inner shell; remove the CTS 70 from the steel frame and grease the interior surfaces.
	CTS 70 is stuck in place.	Check that the CTS 70 pulley carrier can travel the length of the CTS 70 without interfering with any object.



FOR MORE INFORMATION, AND TO FIND THE NEAREST
COVANA RETAILER VISIT OUR WEBSITE:

covana.com info@covana.com



COVANA a division of Canimex,
committed to excellence since 1969.